

TOP VIEW

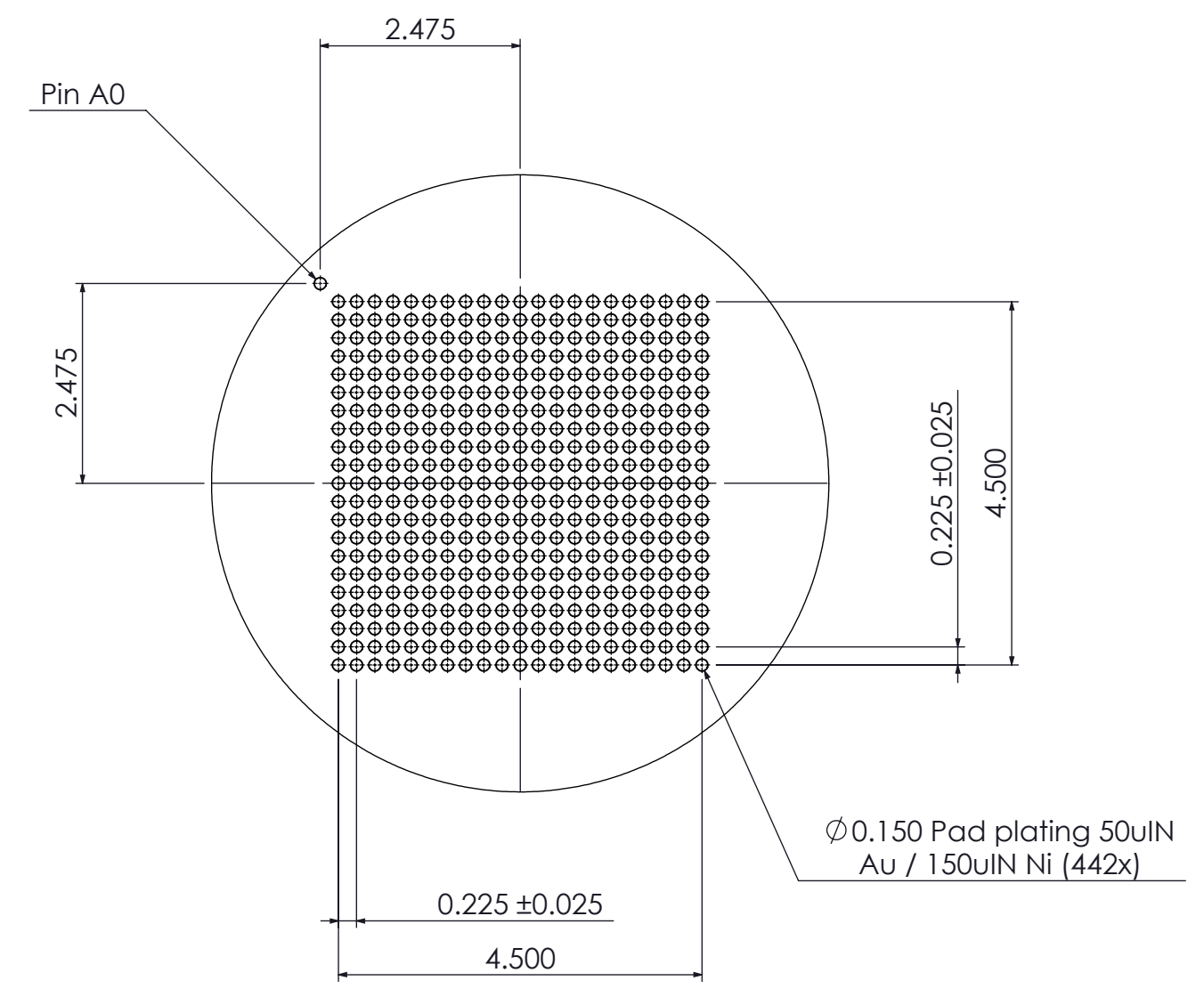

DETAIL A

UNLESS OTHERWISE SPECIFIED:		NAME	DATE	 <small>Contech Solutions Incorporated 631 Montague Avenue San Leandro, CA 94577</small>
<small>DIMENSIONS ARE IN MILLIMETERS TOLERANCES: X ±0.1 XX ±0.05 XXX ±0.025 ANGLES ± 1° • DIMENSIONAL LIMITS APPLY BEFORE PROCESSES • REMOVE ALL BURRS AND SHARP EDGES</small>		DRAWN	J PORTILLO	
MATERIAL		CHECKED	V.MOJICA	03/22/11
FINISH		ENG APPR.		
DO NOT SCALE DRAWING		MFG APPR.		
		Q.A.		
		COMMENTS:		
TITLE:				Footprint drawing for custom socket 0.225mm pitch PN# CSCSP441-0.225-CS400-CHST1
SIZE	DWG. NO.	REV		
C	CSCSP441_0.225_CS400_CHST1	A2		
SCALE		SHEET 1 OF 7		

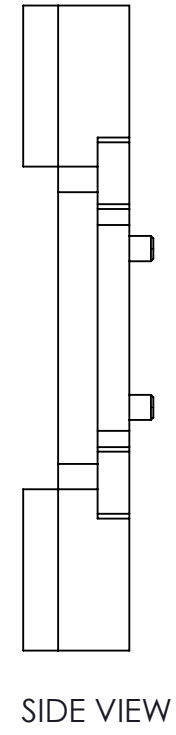
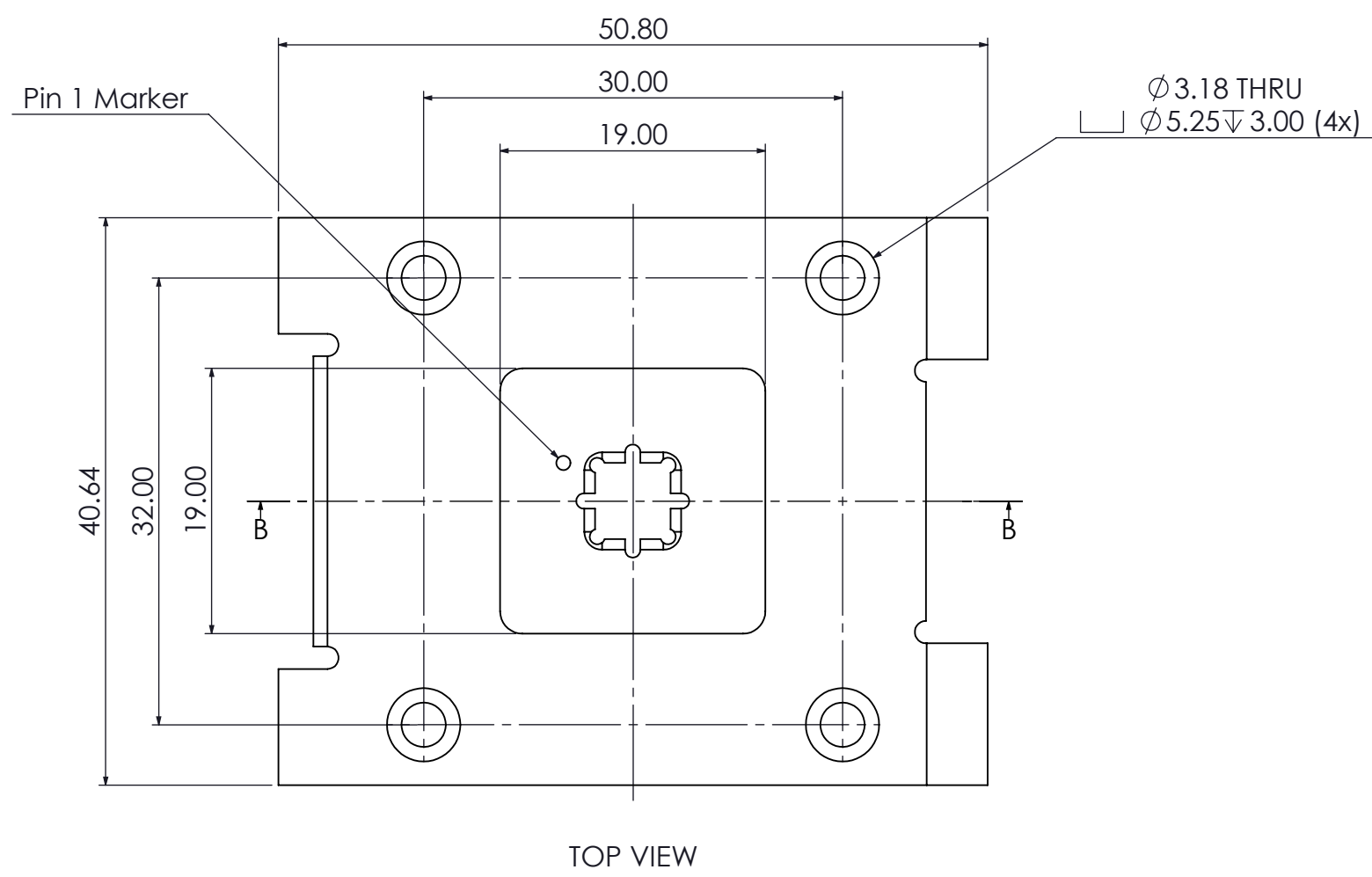

COMPONENTS ARE
2.00mm MAX. HEIGHT (4x)

Ø 1.590 ± 0.015
Sst dowel pin (5x)

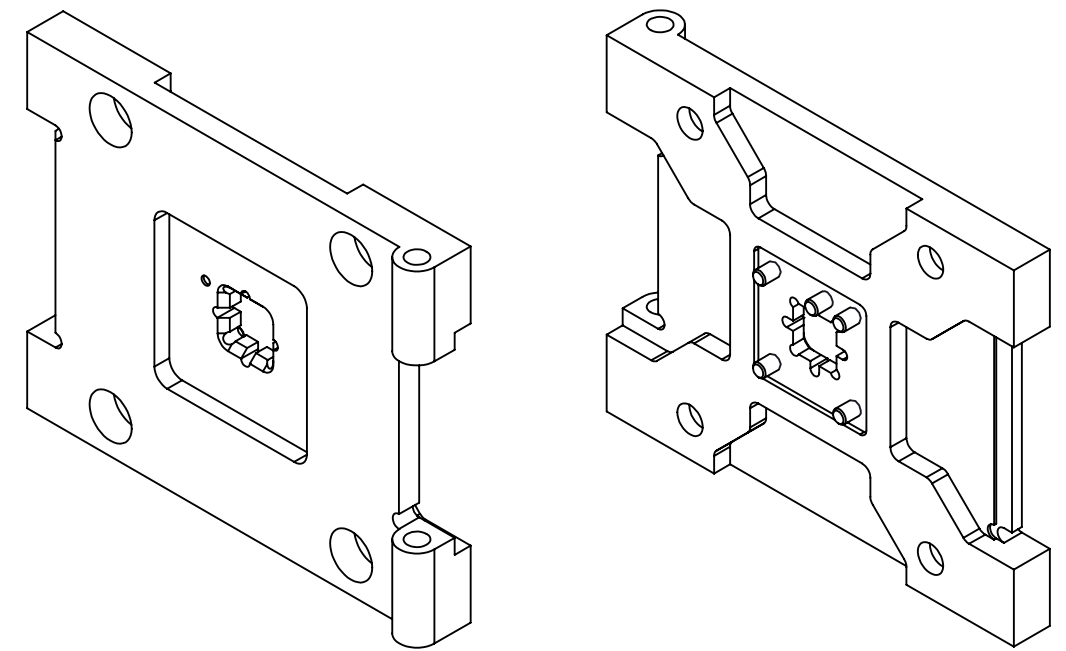
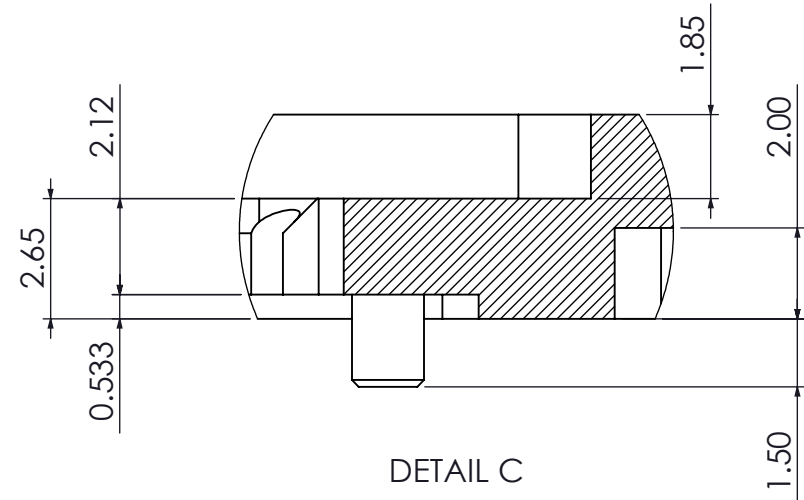
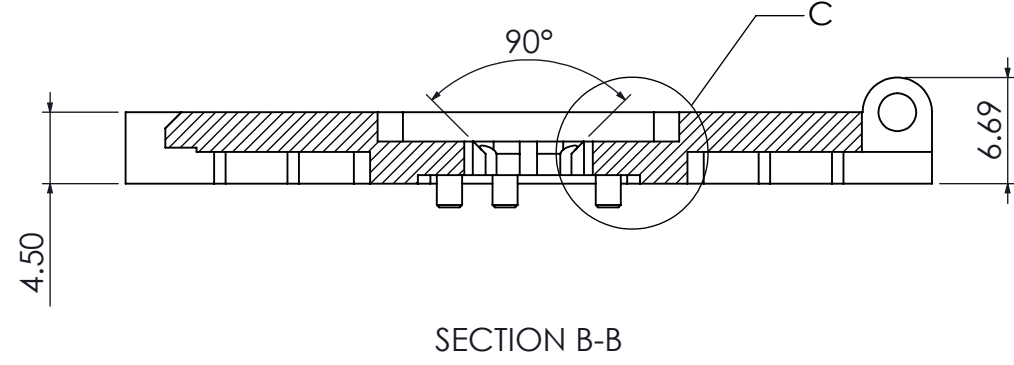
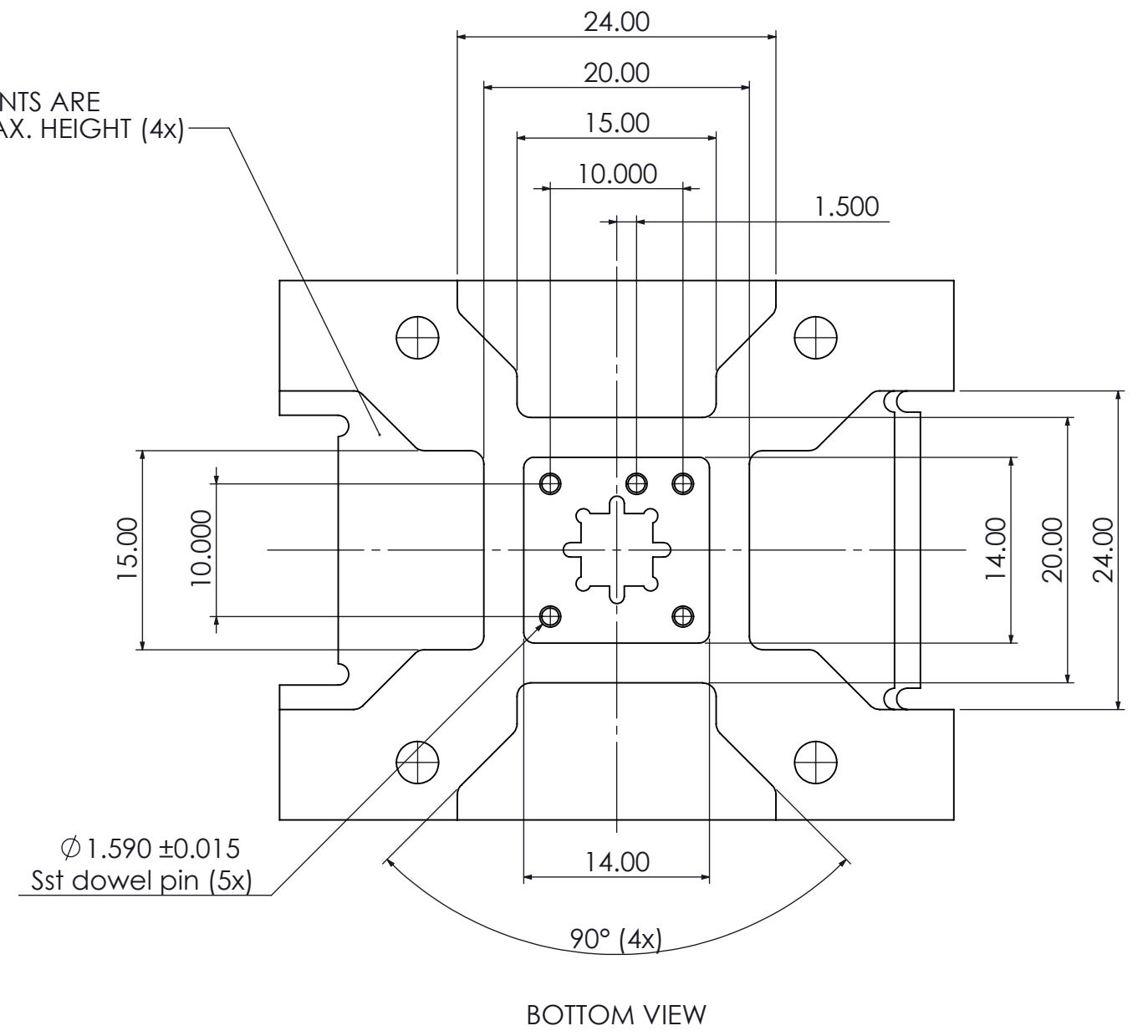

UNLESS OTHERWISE SPECIFIED:		NAME	DATE	 Contech Solutions Incorporated 631 Montague Avenue San Leandro, CA 94577	
DIMENSIONS ARE IN MILLIMETERS		DRAWN	J PORTILLO		03/22/11
TOLERANCES:		CHECKED	V.MOJICA		03/22/11
X	±0.1	ENG APPR.			
XX	±0.05	MFG APPR.			
XXX	±0.025	Q.A.			
ANGLES ± 1°		COMMENTS:			
• DIMENSIONAL LIMITS APPLY BEFORE PROCESSES					
• REMOVE ALL BURRS AND SHARP EDGES					
MATERIAL	Aluminum			TITLE:	
FINISH	Red Anodized			Drawing for custom socket 0.225mm pitch	
DO NOT SCALE DRAWING				PN# CSCSP441-0.225-CS400-CHST1	
SIZE	DWG. NO.			REV	
C	CSCSP441_0.225_CS400_CHST1			A2	
SCALE			SHEET 2 OF 7		

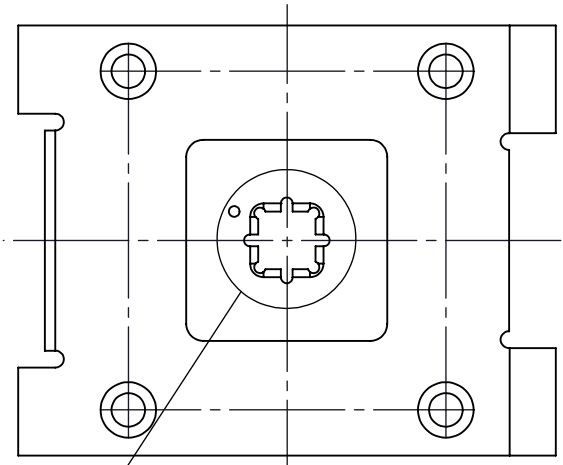

TOP VIEW

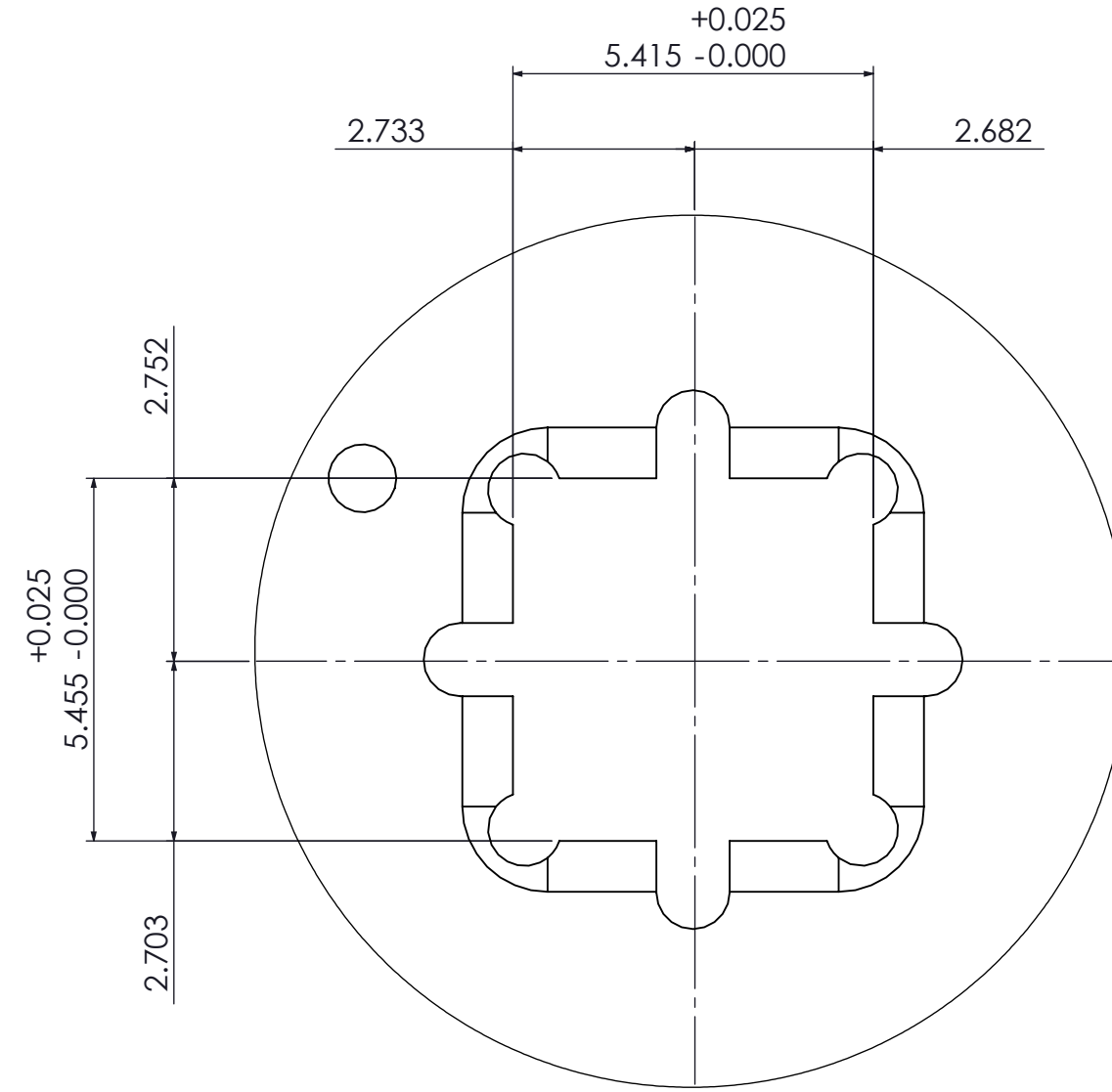

DETAIL D

UNLESS OTHERWISE SPECIFIED:		NAME	DATE	 Cortech Solutions Incorporated 631 Montague Avenue San Leandro, CA 94577	
DIMENSIONS ARE IN MILLIMETERS		DRAWN	J.PORTILLO		03/22/11
TOLERANCES:		CHECKED	V.MOJICA		03/22/11
X	±0.1	ENG APPR.			
XX	±0.05	MFG APPR.			
XXX	±0.025	Q.A.			
ANGLES ± 1°		COMMENTS:			
• DIMENSIONAL LIMITS APPLY BEFORE PROCESSES					
• REMOVE ALL BURRS AND SHARP EDGES					
MATERIAL	Aluminum			TITLE: Drawing for custom socket 0.225mm pitch PN# CSCSP441-0.225-CS400-CHST1	
FINISH	Red Anodized				
DO NOT SCALE DRAWING		SIZE	DWG. NO.	REV	
		C	CSCSP441_0.225_CS400_CHST1	A2 04/12/11	
		SCALE		SHEET 3 OF 7	

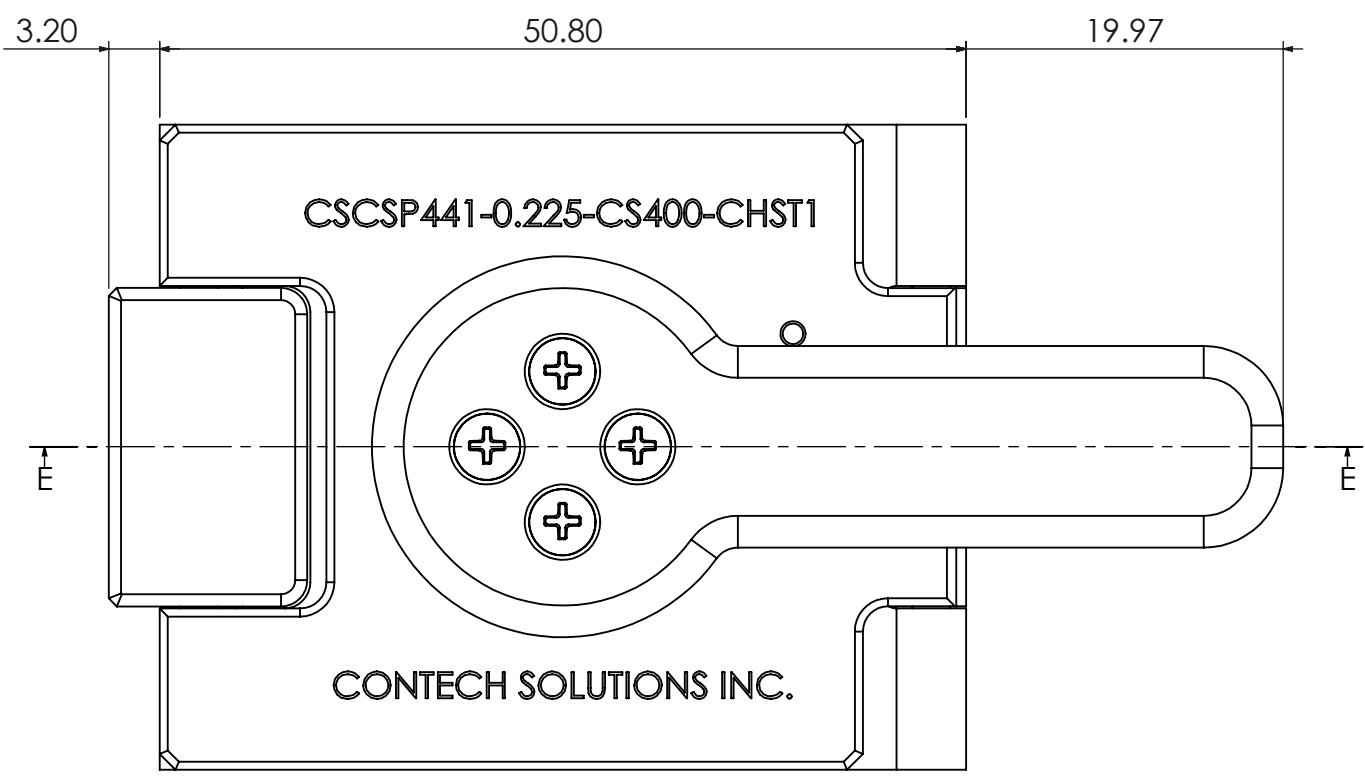

TOP VIEW

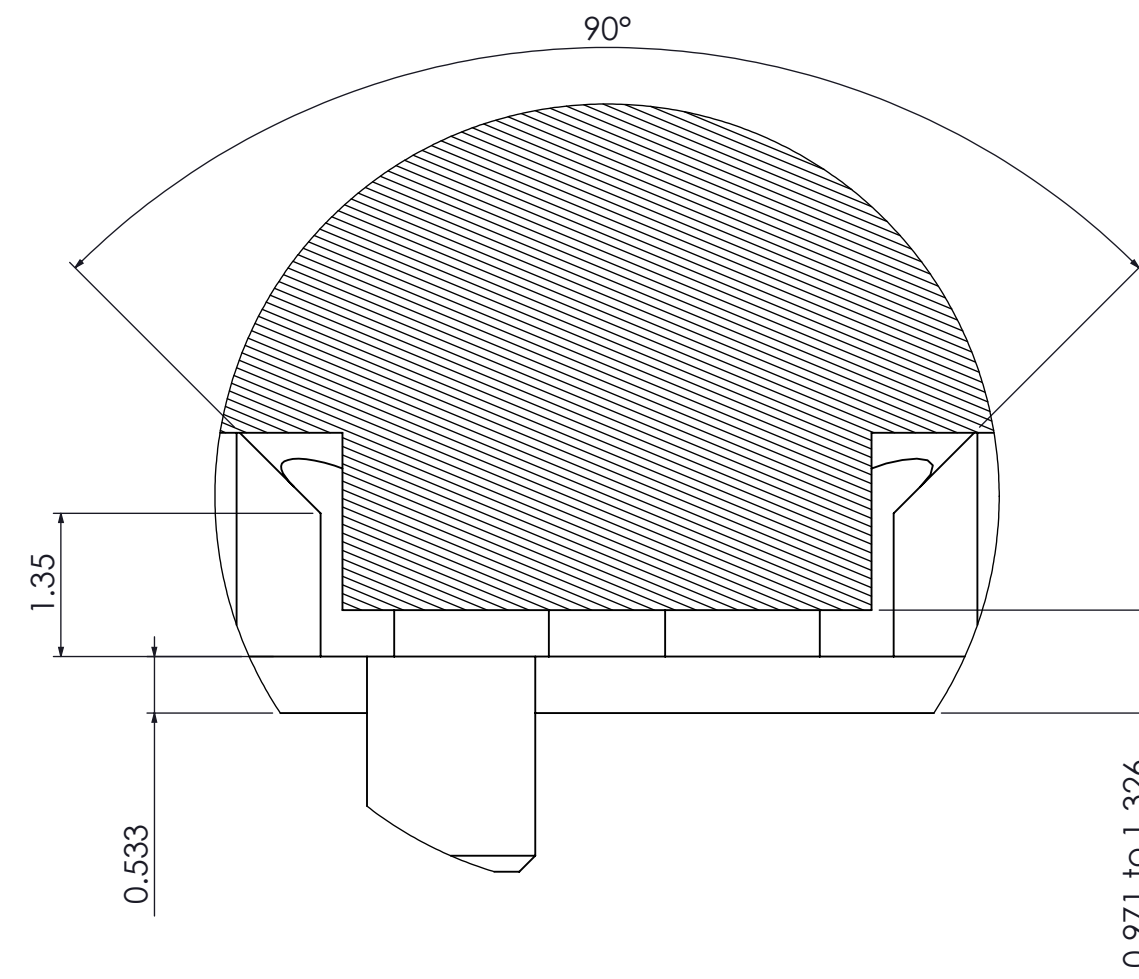
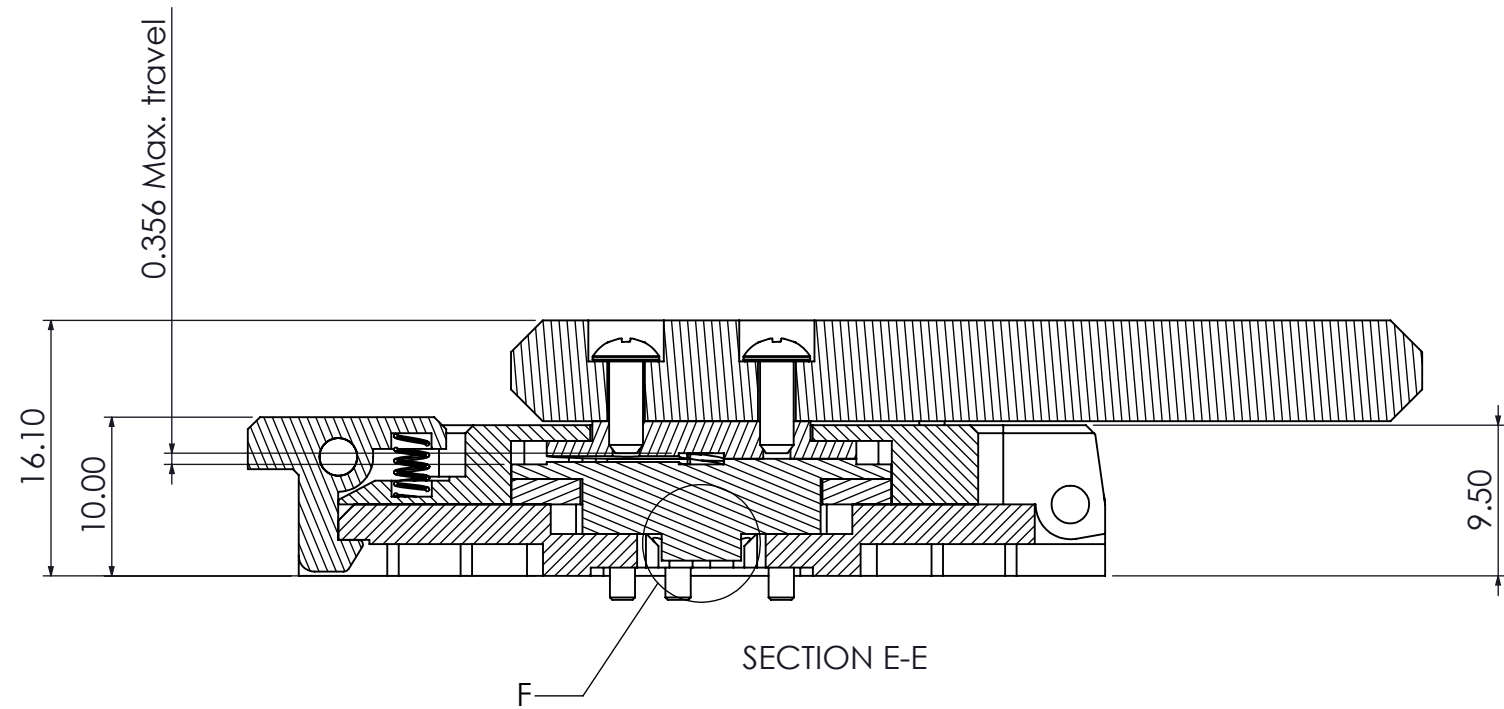

DETAIL F

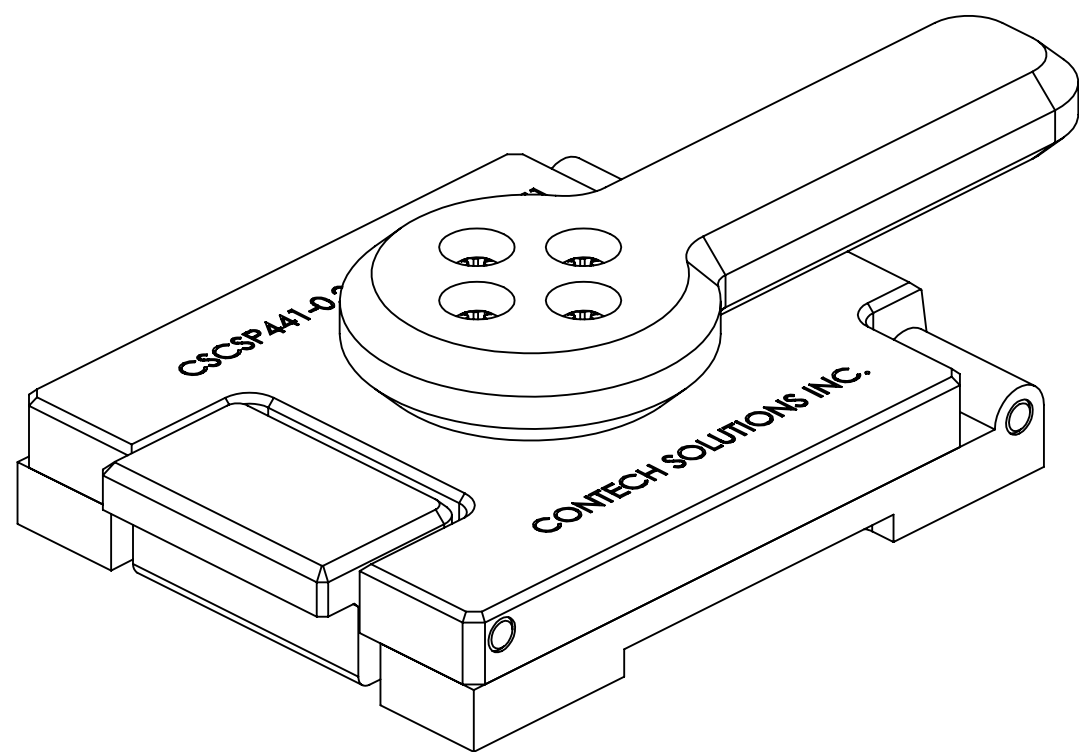

UNLESS OTHERWISE SPECIFIED:		NAME	DATE	 Contech Solutions Incorporated 631 Montague Avenue San Leandro, CA 94577	
DIMENSIONS ARE IN MILLIMETERS		DRAWN	J.PORTILLO		03/22/11
TOLERANCES:		CHECKED	V.MOJICA		03/22/11
X	±0.1	ENG APPR.			
XX	±0.05	MFG APPR.			
XXX	±0.025	Q.A.			
ANGLES ± 1°		COMMENTS:			
• DIMENSIONAL LIMITS APPLY BEFORE PROCESSES					
• REMOVE ALL BURRS AND SHARP EDGES					
MATERIAL					
FINISH					
DO NOT SCALE DRAWING					
TITLE:				Drawing for custom socket 0.225mm pitch PN# CSCSP441-0.225-CS400-CHST1	
SIZE	DWG. NO.	REV			
C	CSCSP441_0.225_CS400_CHST1	A2			
SCALE		SHEET 4 OF 7			

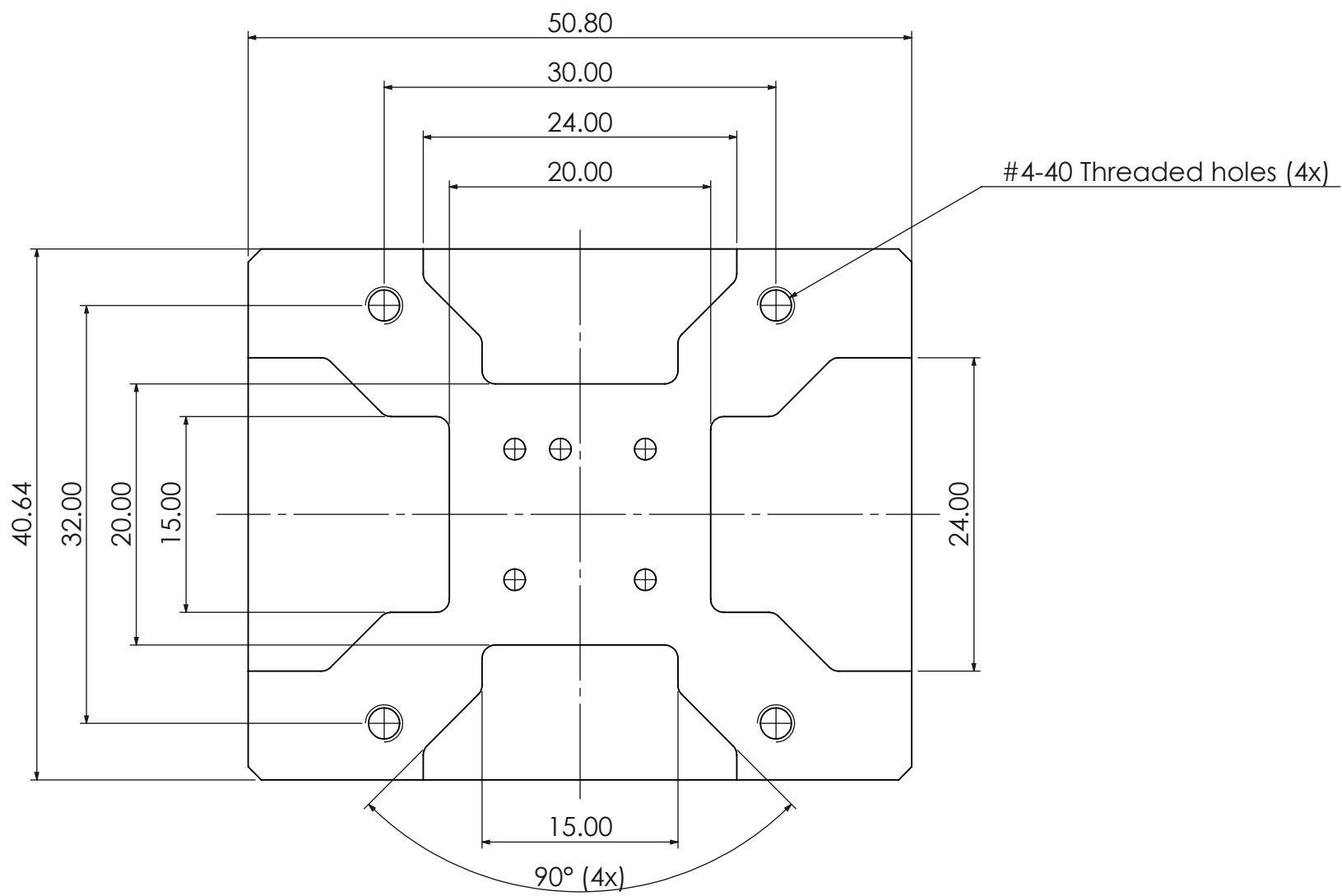

TOP VIEW

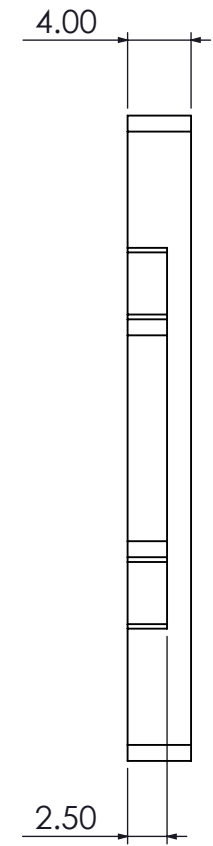

SIDE VIEW

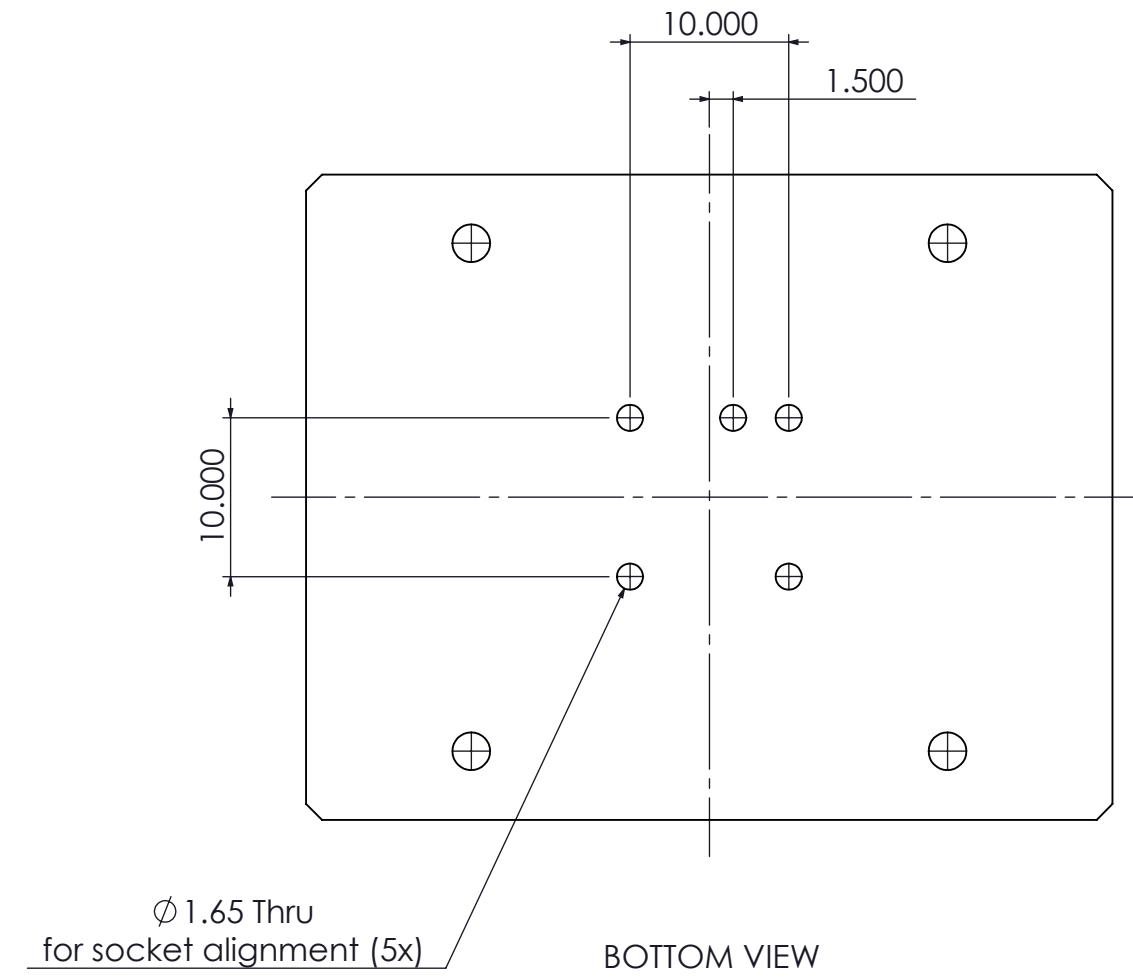

BOTTOM VIEW

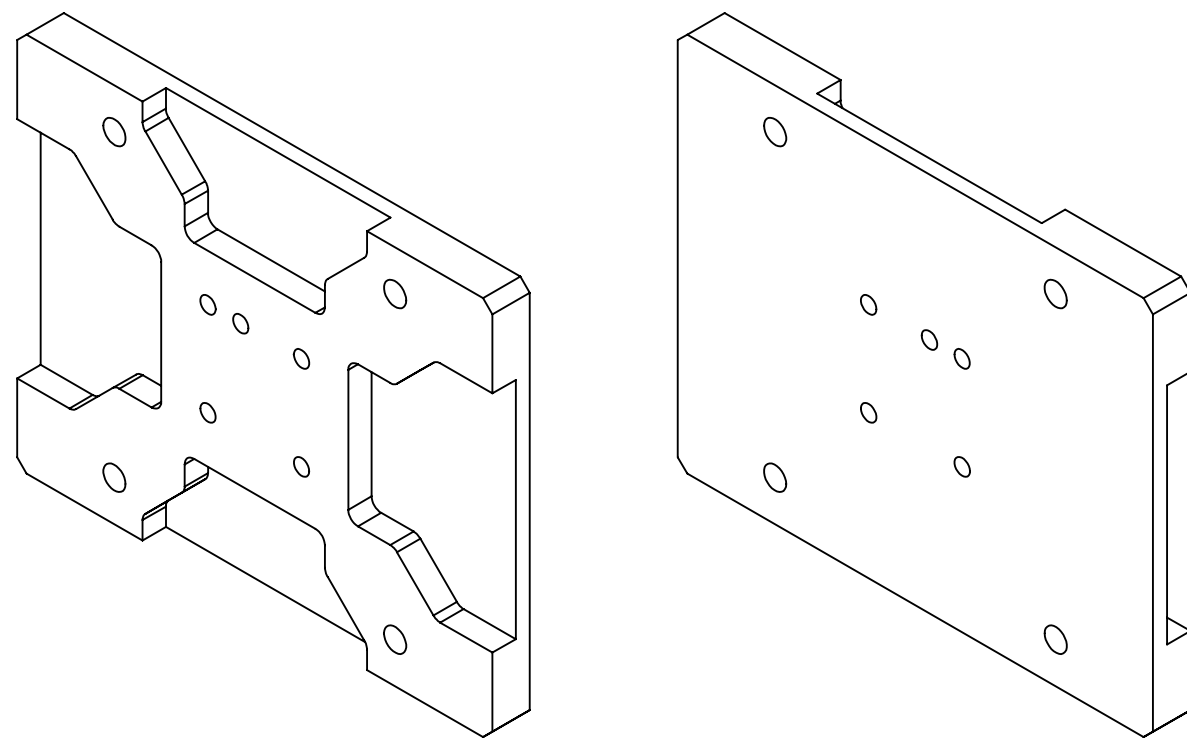

UNLESS OTHERWISE SPECIFIED:		NAME	DATE	 Cortech Solutions Incorporated 631 Montague Avenue San Leandro, CA 94577	
DIMENSIONS ARE IN MILLIMETERS		DRAWN	J.PORTILLO		03/22/11
TOLERANCES:		CHECKED	V.MOJICA		03/22/11
X	±0.1	ENG APPR.			
XX	±0.05	MFG APPR.			
XXX	±0.025	Q.A.			
ANGLES ± 1°		COMMENTS:			
• DIMENSIONAL LIMITS APPLY BEFORE PROCESSES					
• REMOVE ALL BURRS AND SHARP EDGES					
MATERIAL	Aluminum				
FINISH					
DO NOT SCALE DRAWING					
TITLE:				Drawing for custom socket 0.225mm pitch PN# CSCSP441-0.225-CS400-CHST1	
SIZE	DWG. NO.	REV			
C	CSCSP441_0.225_CS400_CHST1	A2			
SCALE		SHEET 5 OF 7			

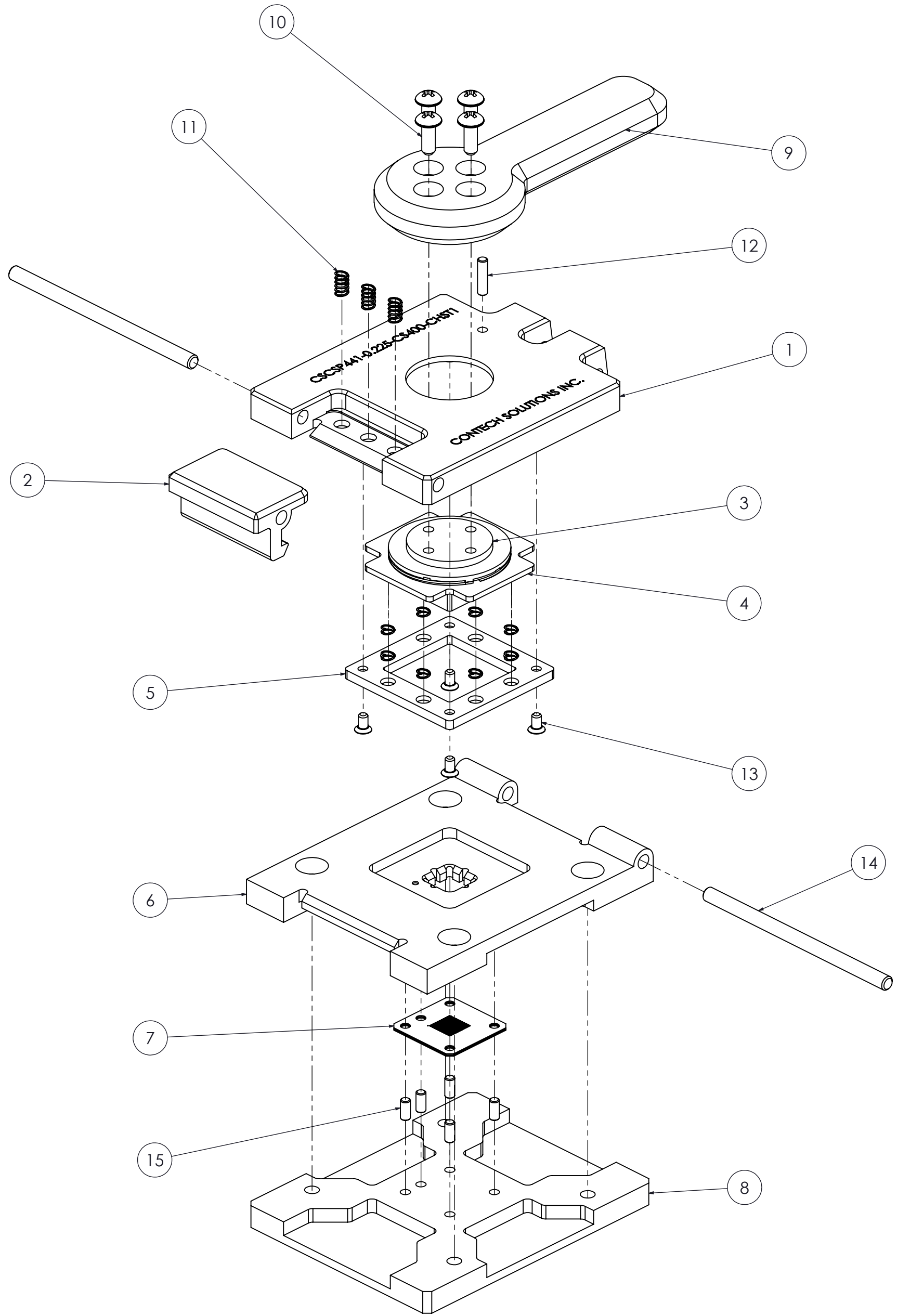

PART LIST			
ITEM NO.	QTY.	PART NUMBER	DESCRIPTION
1	1	CSCSP441-0.225-CS400-CHST1-LID	ALUMINUM, LID
2	1	CSCSP441-0.225-CS400-CHST1-LT	ALUMINUM, LATCH
3	1	CSCSP441-0.225-CS400-CHST1-RTO	PEEK, ROTATOR
4	1	CSCSP441-0.225-CS400-CHST1-PLG	PEEK, PLUNGER
5	1	CSCSP441-0.225-CS400-CHST1-RTN	ALUMINUM, RETAINER
6	1	CSCSP441-0.225-CS400-CHST1-SKT	ALUMINUM, CONTACTOR BASE
7	1	CS400	INTERPOSER
8	1	CSCSP441-0.225-CS400-CHST1-STF	ALUMINUM, STIFFENER
9	1	CSCSP441-0.225-CS400-CHST1	ALUMINUM, HANDLER
10	4	2C18PNHD	#2-56 X 3/16" UNC PHIL PAD HEAD SCREW
11	11	N-2	COMPRESSION SPRING
12	1	6R25DOWS	Ø 1/16" X 1/4" SST DOWEL PIN
13	4	0F125PFVS	#0-80 X 1/8" UNC PHIL FLAT HD
14	2	9R160DOWS	Ø 3/32" X 1.60" SST DOWEL PIN
15	5	6R4DOWS	Ø 1.59mm X 4.00mm SST DOWEL PIN

UNLESS OTHERWISE SPECIFIED:		NAME	DATE	Contech Solutions Incorporated 631 Montague Avenue San Leandro, CA 94577	
DIMENSIONS ARE IN MILLIMETERS		DRAWN	J.PORTILLO		03/22/11
TOLERANCES:		CHECKED	V.MOJICA		03/22/11
X	±0.1	ENG APPR.			
XX	±0.05	MFG APPR.			
XXX	±0.025	Q.A.			
ANGLES ± 1°		COMMENTS:			
• DIMENSIONAL LIMITS APPLY BEFORE PROCESSES					
• REMOVE ALL BURRS AND SHARP EDGES					
MATERIAL					
FINISH					
DO NOT SCALE DRAWING					
TITLE:		DRAWING NO.		REV	
Drawing for custom socket 0.225mm pitch		CSCSP441_0.225_CS400_CHST1		A2	
PN# CSCSP441-0.225-CS400-CHST1		SCALE		04/12/11	
		SHEET 6 OF 7			

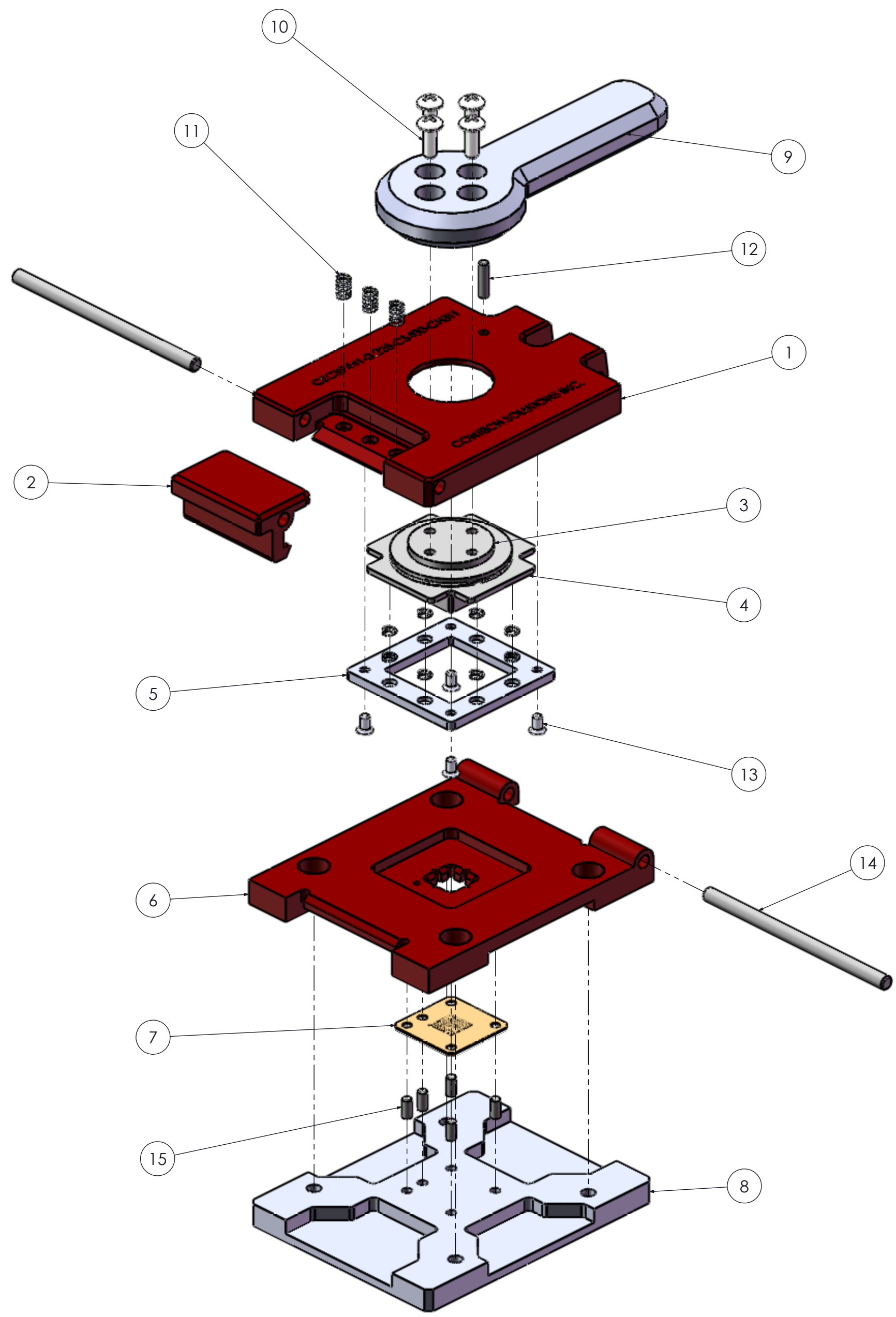

PART LIST			
ITEM NO.	QTY.	PART NUMBER	DESCRIPTION
1	1	CSCSP441-0.225-CS400-CHST1-LID	ALUMINUM, LID
2	1	CSCSP441-0.225-CS400-CHST1-LT	ALUMINUM, LATCH
3	1	CSCSP441-0.225-CS400-CHST1-RTO	PEEK, ROTATOR
4	1	CSCSP441-0.225-CS400-CHST1-PLG	PEEK, PLUNGER
5	1	CSCSP441-0.225-CS400-CHST1-RTN	ALUMINUM, RETAINER
6	1	CSCSP441-0.225-CS400-CHST1-SKT	ALUMINUM, CONTACTOR BASE
7	1	CS400	INTERPOSER
8	1	CSCSP441-0.225-CS400-CHST1-STF	ALUMINUM, STIFFENER
9	1	CSCSP441-0.225-CS400-CHST1	ALUMINUM, HANDLER
10	4	2C18PNHD	#2-56 X 3/16" UNC PHIL PAD HEAD SCREW
11	11	N-2	COMPRESSION SPRING
12	1	6R25DOWS	Ø 1/16" X 1/4" SST DOWEL PIN
13	4	0F125PFVS	#0-80 X 1/8" UNC PHIL FLAT HD
14	2	9R160DOWS	Ø 3/32" X 1.60" SST DOWEL PIN
15	5	6R4DOWS	Ø 1.59mm X 4.00mm SST DOWEL PIN

UNLESS OTHERWISE SPECIFIED: DIMENSIONS ARE IN MILLIMETERS TOLERANCES: X ±0.1 XX ±0.05 XXX ±0.025 ANGLES ±1° • DIMENSIONAL LIMITS APPLY BEFORE PROCESSES • REMOVE ALL BURRS AND SHARP EDGES		DRAWN J.PORTILLO 03/22/11	NAME V.MOJICA 03/22/11	DATE 03/22/11	 Cortech Solutions Incorporated 631 Montague Avenue San Leandro, CA 94577
MATERIAL	ENG APPR.	TITLE: Drawing for custom socket 0.225mm pitch PN# CSCSP441-0.225-CS400-CHST1			
FINISH	MFG APPR.	SIZE C DWG. NO. CSCSP441_0.225_CS400_CHST1			
DO NOT SCALE DRAWING	Q.A.	REV A2 04/12/11			
		COMMENTS:		SCALE	SHEET 7 OF 7