

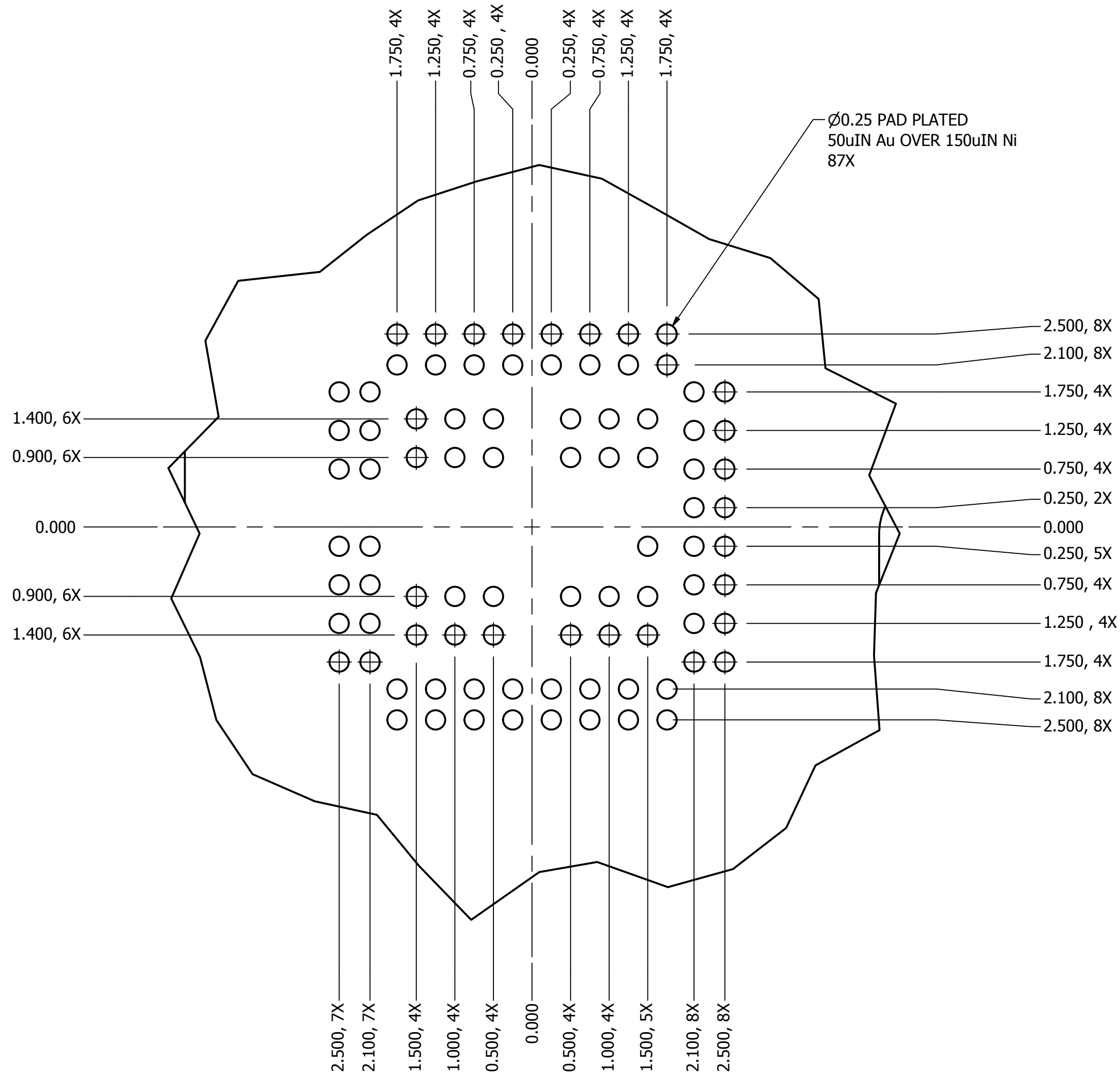

TOP VIEW
SCALE 5 : 1

UNLESS OTHERWISE SPECIFIED DIMENSIONS ARE IN MILLIMETERS TOLERANCES DECIMALS .X ± .1 .XX ± .05 .XXX ± .030 ANGLES ±1°	DRAWN V Mojica	8/15/2016	 Contech Solutions Incorporated 631 Montague avenue San Leandro, Ca 94577		
	CHECKED	12/2/2016			
	QA		TITLE FOOTPRINT DRAWING FOR QFN31 5.0X5.0, 0.5 PITCH PN# CSQFN31-0.5-CS1512-FCH1		
	MFG		SIZE C	DWG NO CSQFN31-CS1512-FCH1	REV A3
	APPROVED		SCALE	SHEET 1 OF 9	
MATERIAL					

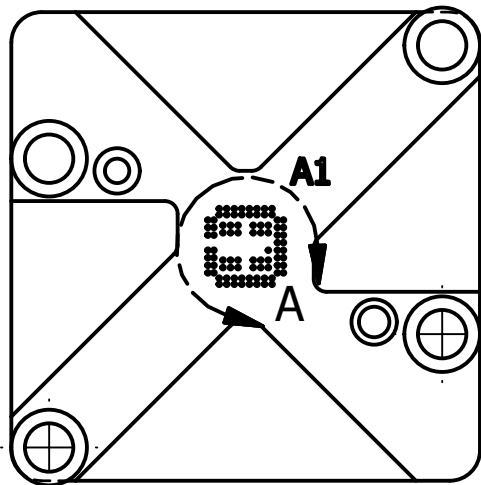

DETAIL A
SCALE 20: 1

UNLESS OTHERWISE SPECIFIED DIMENSIONS ARE IN MILLIMETERS	DRAWN V Mojica	8/15/2016	 Contech Solutions Incorporated 631 Montague avenue San Leandro, Ca 94577
	CHECKED	12/2/2016	
TOLERANCES DECIMALS .X ± .1 .XX ± .05 .XXX ± .030 ANGLES ±1°	QA		TITLE
	MFG		PN# CSQFN31-0.5-CS1512-FCH1
	APPROVED		SIZE C
	MATERIAL		DWG NO CSQFN31-CS1512-FCH1
			REV A3
			SCALE
			SHEET 2 OF 9

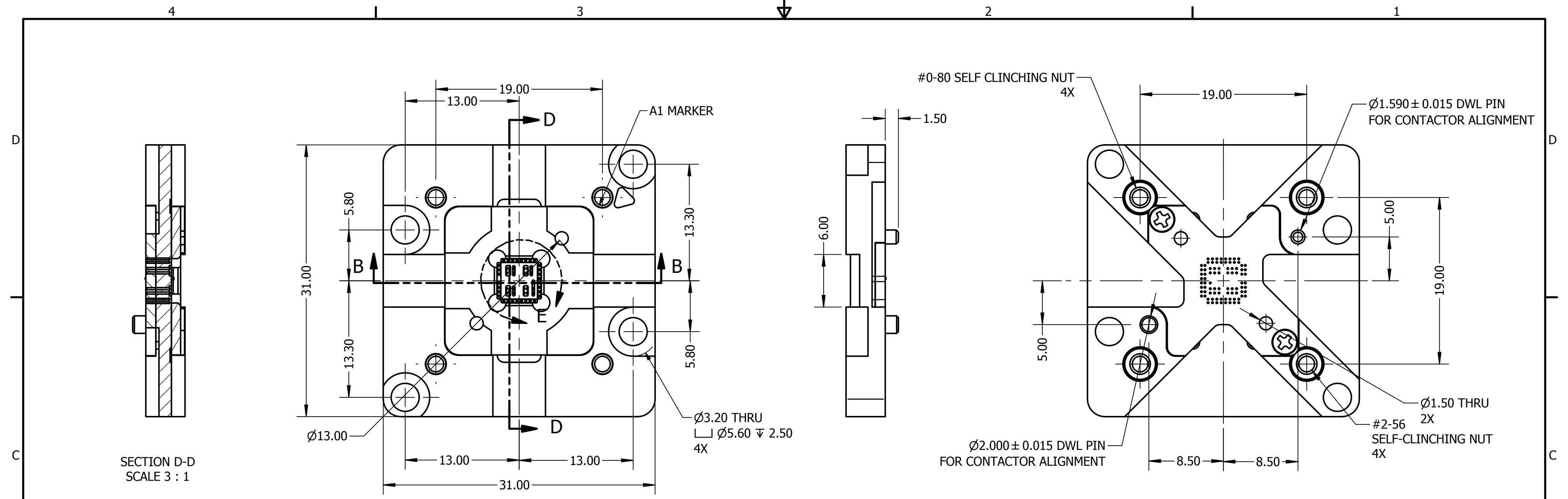

SECTION D-D
SCALE 3 : 1

SECTION B-B
SCALE 3 : 1

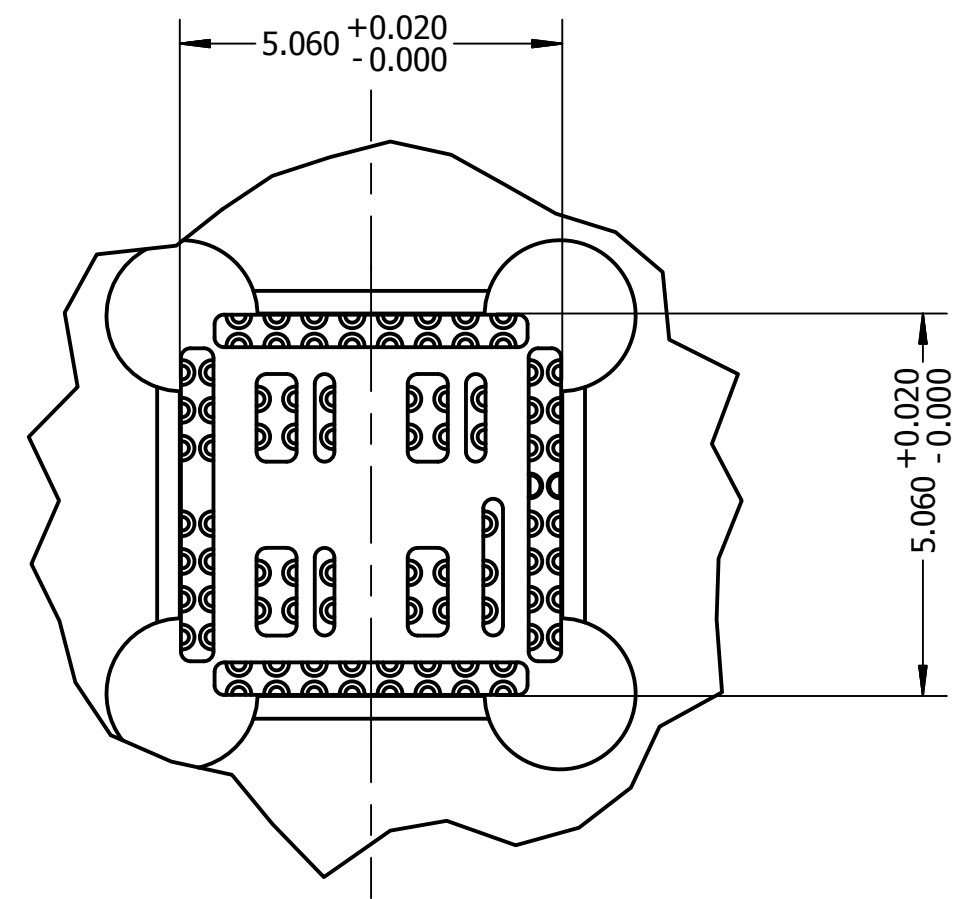

DETAIL E
SCALE 10: 1

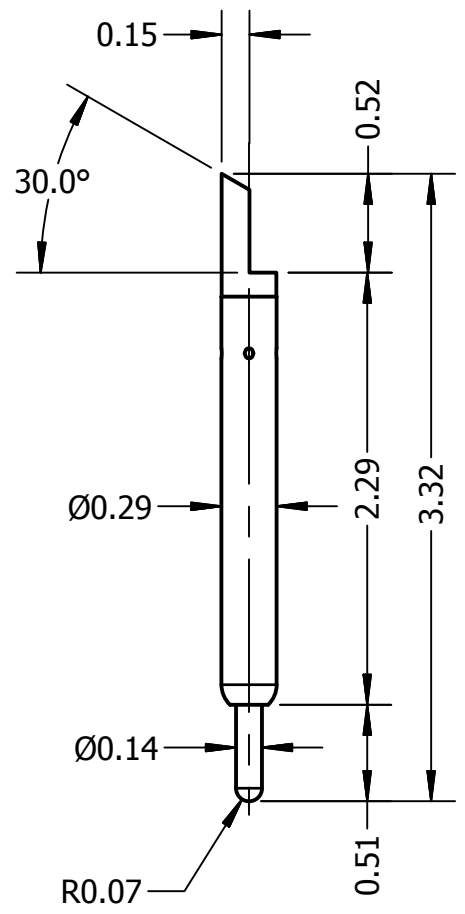

PIN CONTACT DETAIL
SCALE 25 : 1
CS1512-T2

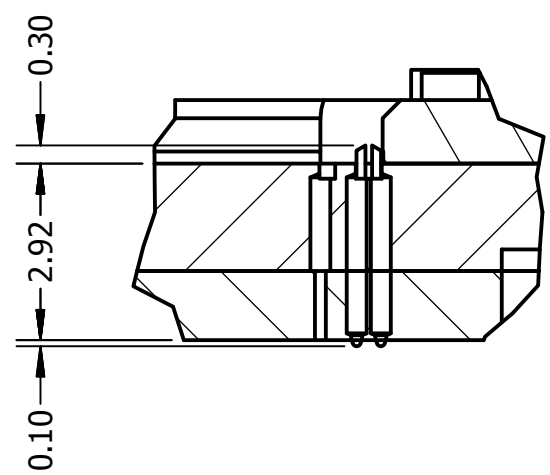

DETAIL C
SCALE 8 : 1

UNLESS OTHERWISE SPECIFIED DIMENSIONS ARE IN MILLIMETERS TOLERANCES DECIMALS .X ± .1 .XX ± .05 .XXX ± .030 ANGLES ±1'	DRAWN V Mojica	8/15/2016	 Contech Solutions Incorporated 631 Montague avenue San Leandro, Ca 94577
	CHECKED	12/2/2016	
	QA		TITLE CUSTOM CONTACTOR DRAWING FOR QFN40 6.0X6.0, 0.5 PITCH PN# CSQFN31-0.5-CS1512-FCH1
	MFG		SIZE C
APPROVED		DWG NO CSQFN31-CS1512-FCH1	REV A3
MATERIAL		SCALE	
			SHEET 3 OF 9

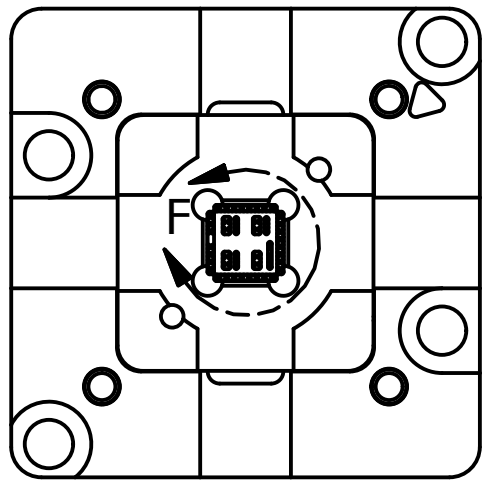

TOP VIEW
SCALE 2: 1

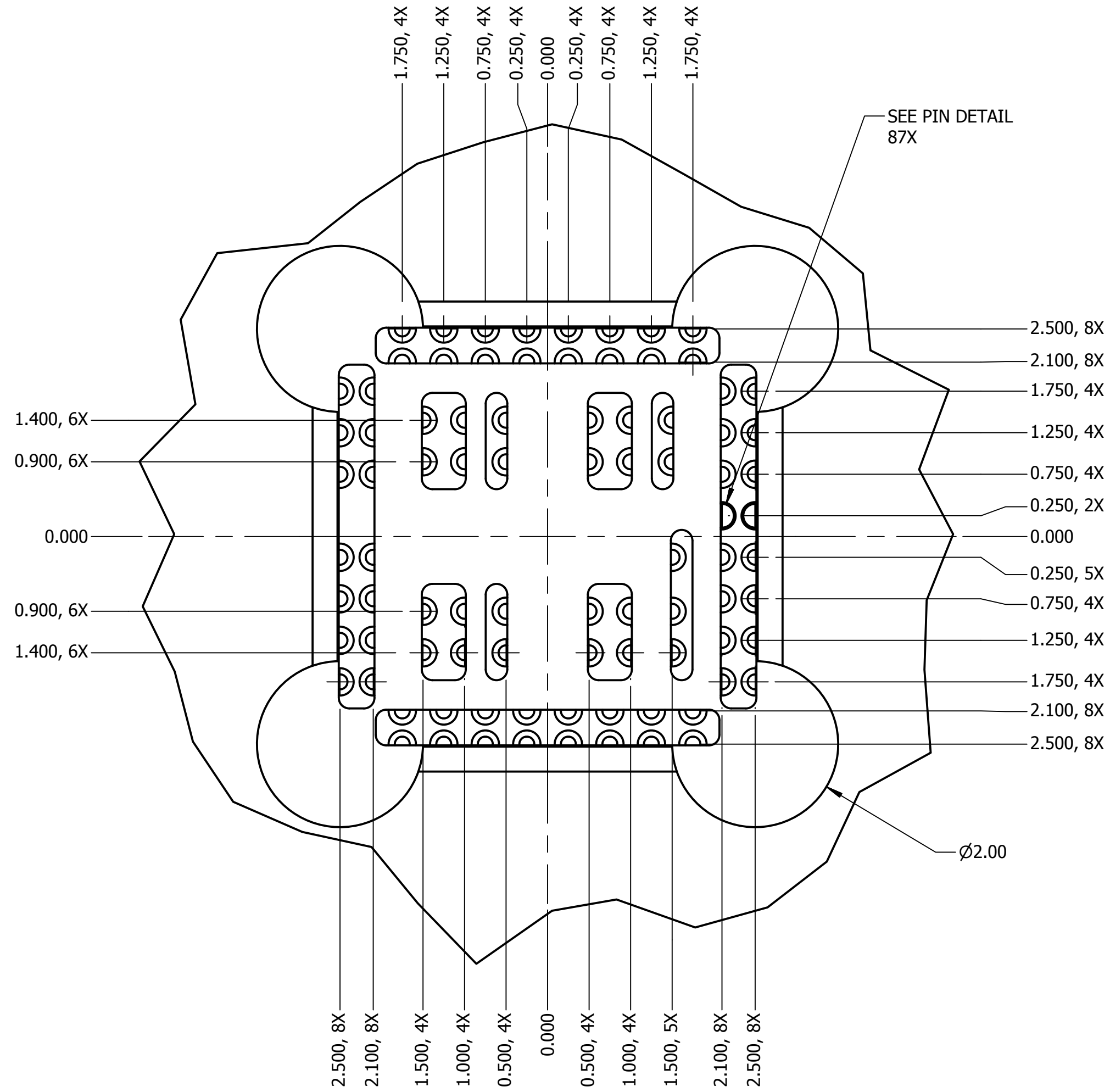

DETAIL F
SCALE 20: 1

UNLESS OTHERWISE SPECIFIED DIMENSIONS ARE IN MILLIMETERS	DRAWN V Mojica	8/15/2016	 Contech Solutions Incorporated 631 Montague avenue San Leandro, Ca 94577
	CHECKED	12/2/2016	
TOLERANCES DECIMALS .X ± .1 .XX ± .05 .XXX ± .030 ANGLES ±1°	QA		TITLE
	MFG		PN# CSQFN31-0.5-CS1512-FCH1
	APPROVED		SIZE C
	MATERIAL		DWG NO CSQFN31-CS1512-FCH1
			REV A3
			SCALE
			SHEET 4 OF 9

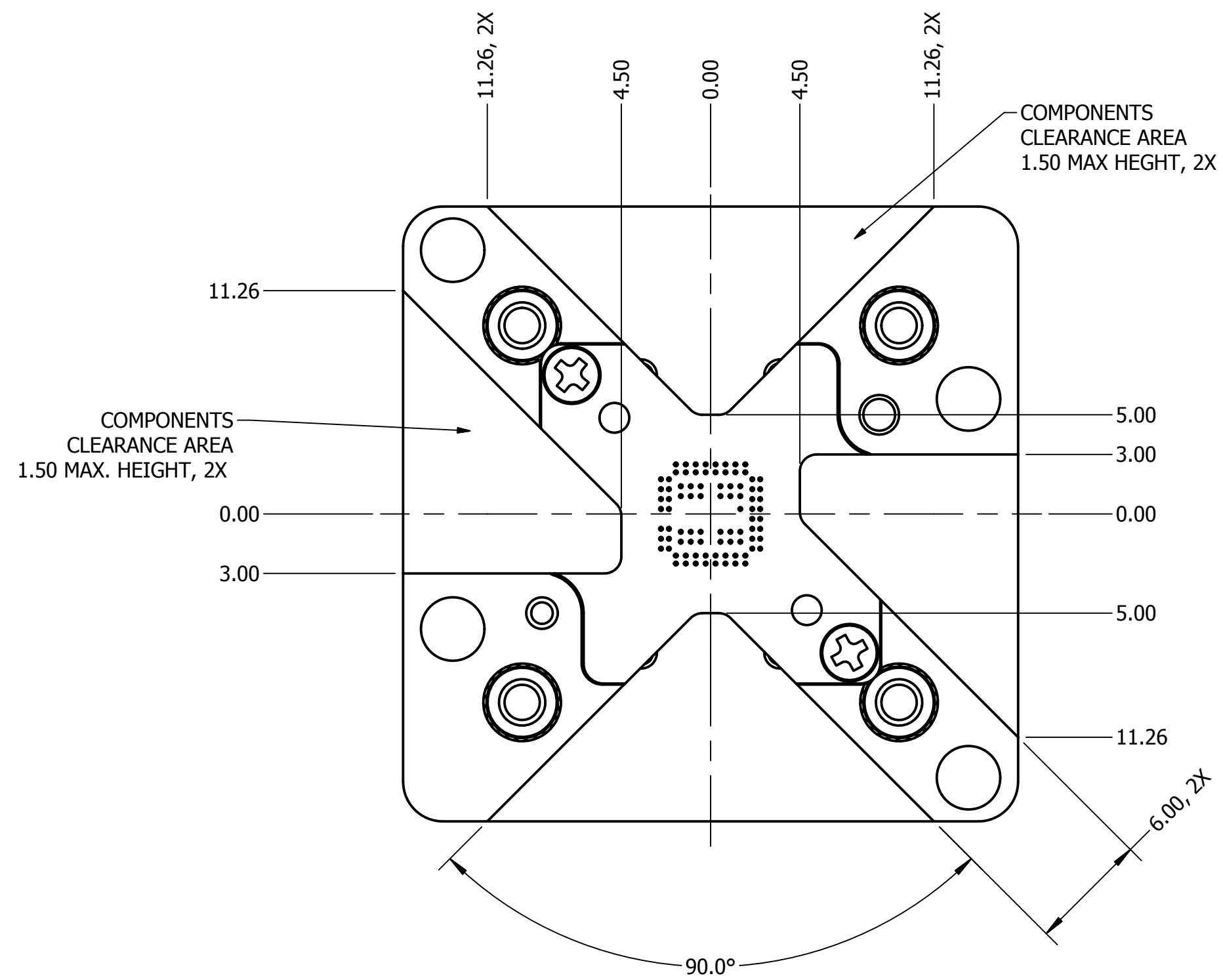

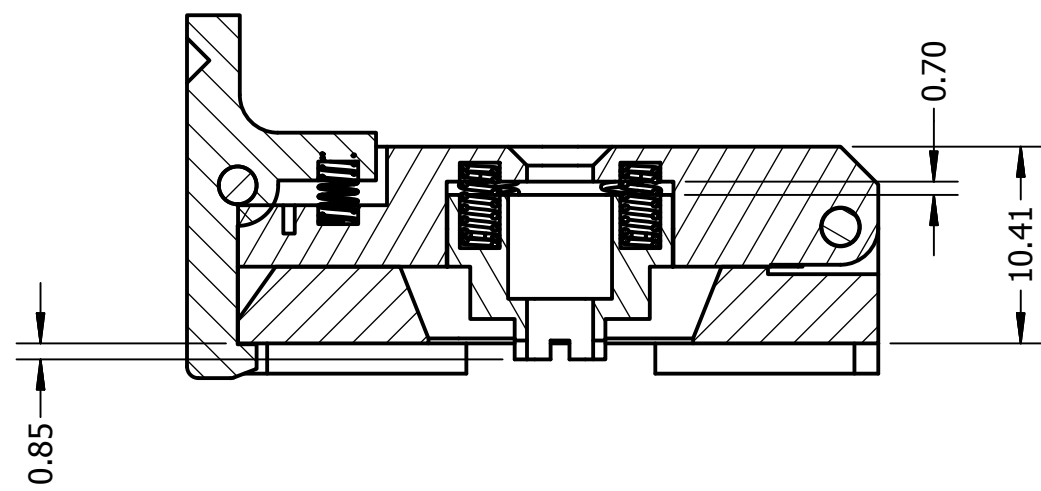
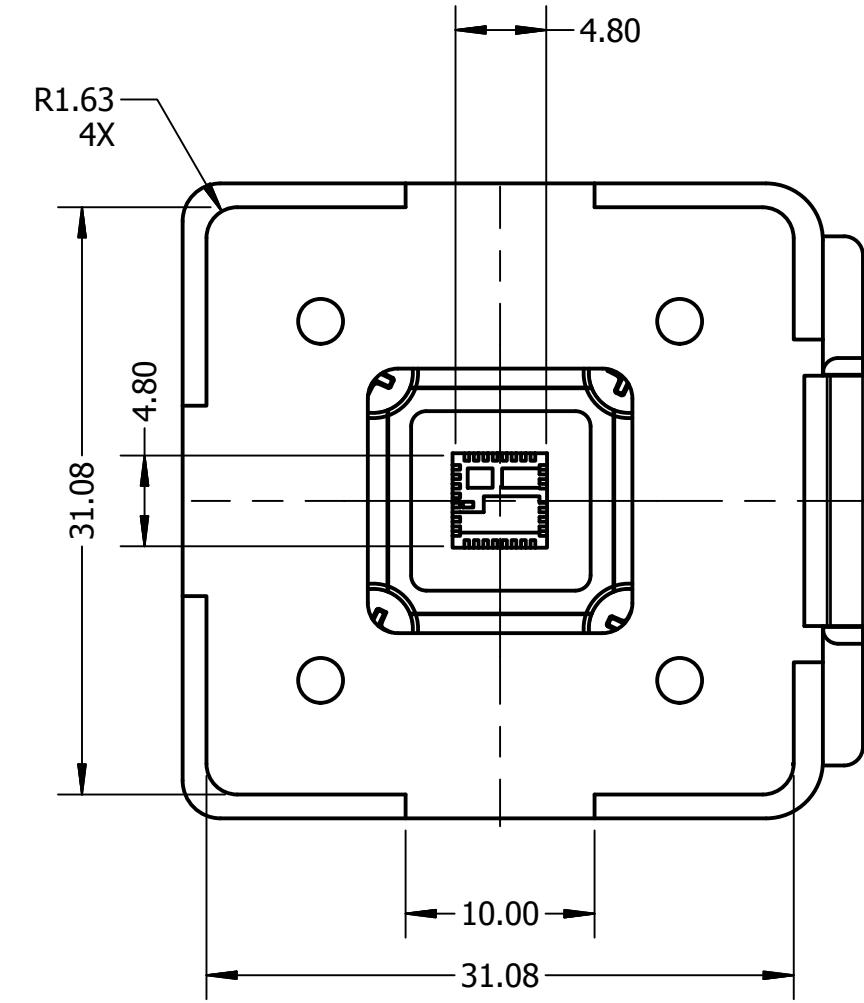
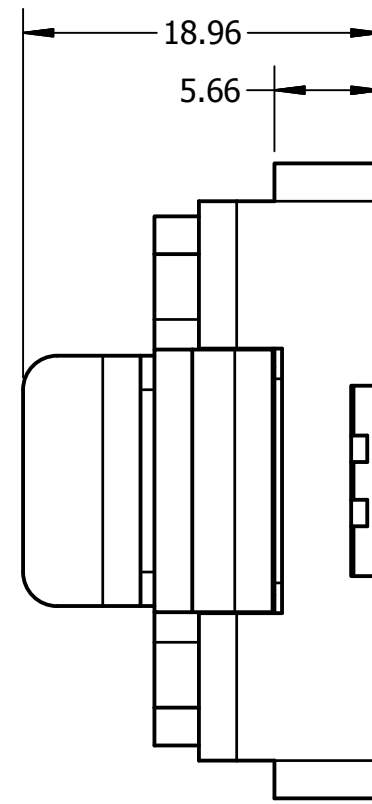
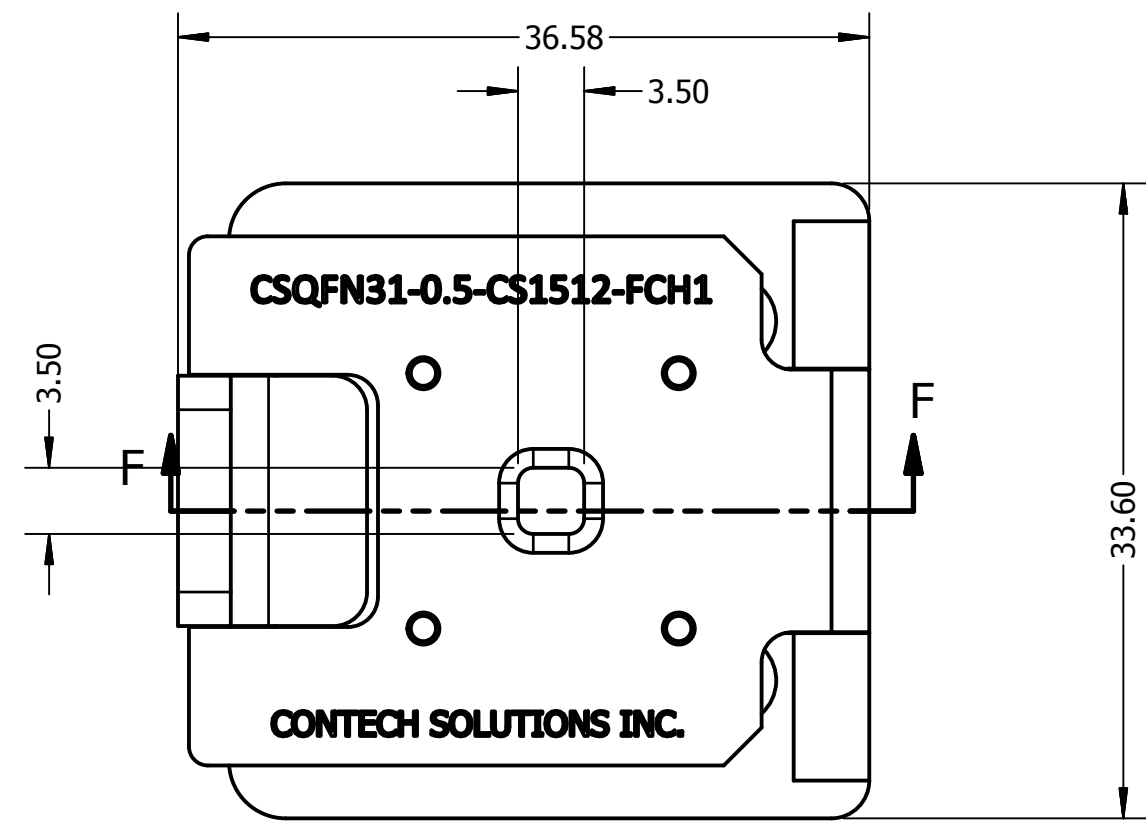

BOTTOM VIEW
SCALE 4 : 1

UNLESS OTHERWISE SPECIFIED DIMENSIONS ARE IN MILLIMETERS TOLERANCES DECIMALS .X ± .1 .XX ± .05 .XXX ± .030 ANGLES ±1°	DRAWN V Mojica 8/15/2016	 Contech Solutions Incorporated 631 Montague avenue San Leandro, Ca 94577	TITLE PN# CSQFN31-0.5-CS1512-FCH1		
	CHECKED QA 12/2/2016				
	MFG		SIZE C	DWG NO CSQFN31-CS1512-FCH1	REV A3
	APPROVED		SCALE	SHEET 5 OF 9	
	MATERIAL				

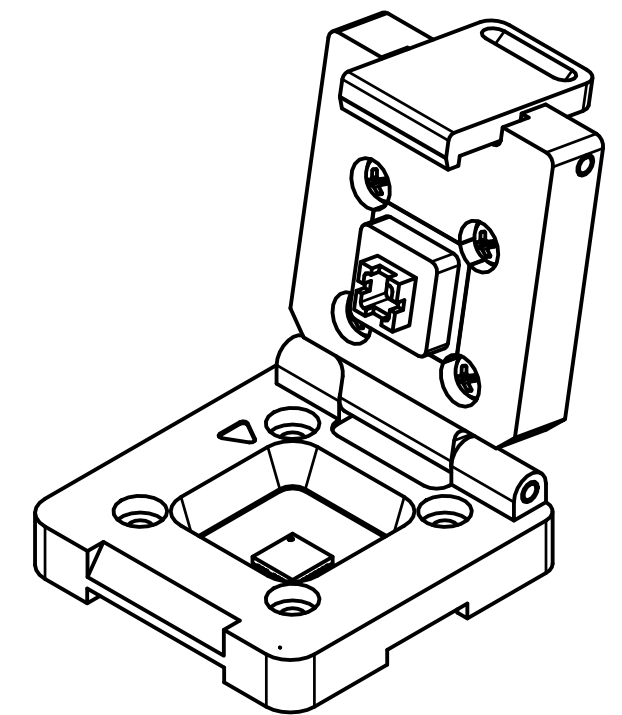
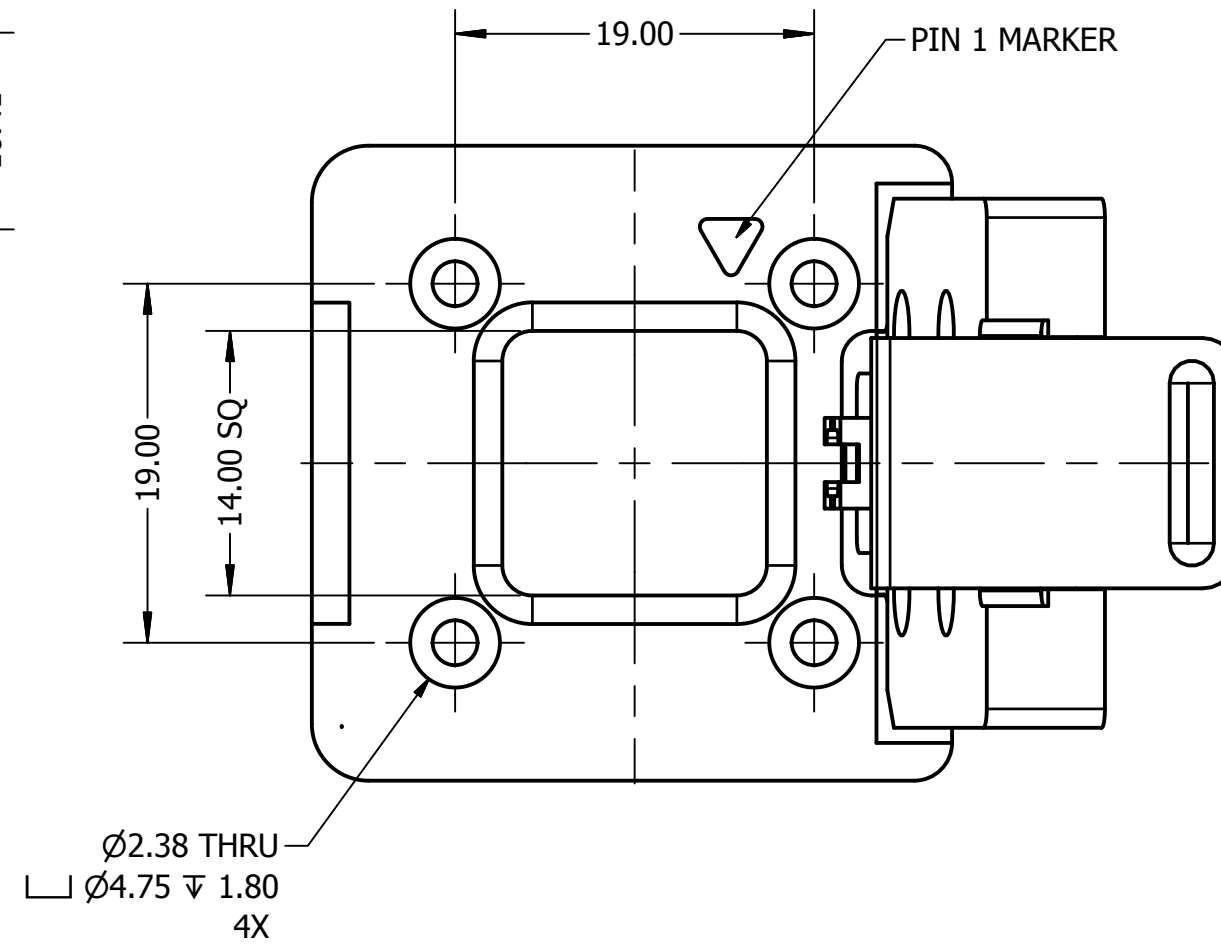

SECTION F-F
SCALE 2.5



UNLESS OTHERWISE SPECIFIED DIMENSIONS ARE IN MILLIMETERS TOLERANCES DECIMALS .X ± .1 .XX ± .05 .XXX ± .030 ANGLES ±1'	DRAWN V Mojica	8/15/2016	 Contech Solutions Incorporated 631 Montague avenue San Leandro, Ca 94577
	CHECKED	12/2/2016	
	QA		TITLE
	MFG		PN# CSQFN31-0.5-CS1512-FCH1
	APPROVED		SIZE C
	MATERIAL		DWG NO CSQFN31-CS1512-FCH1
			REV A3
			SCALE
			SHEET 6 OF 9

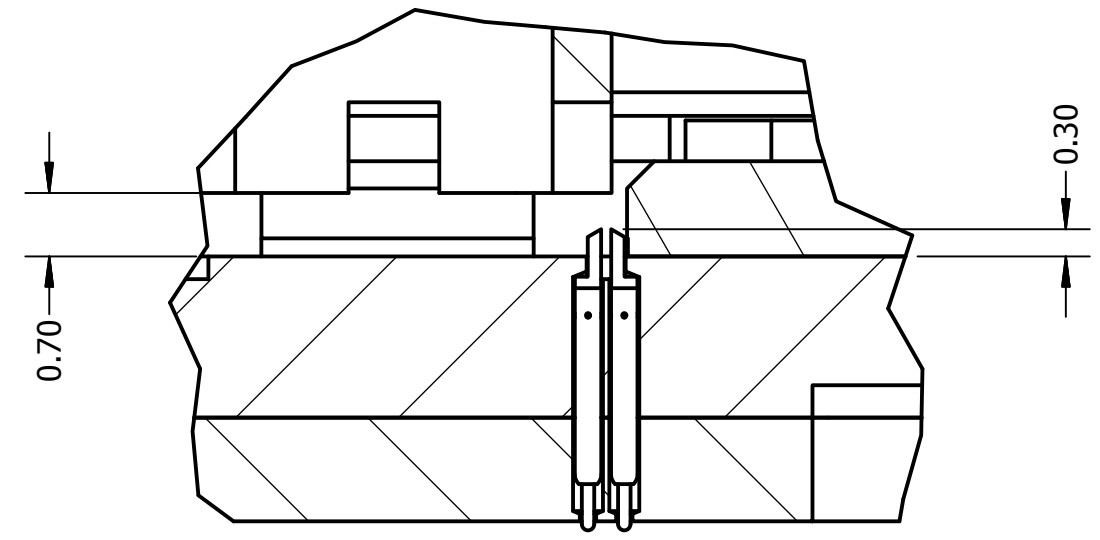
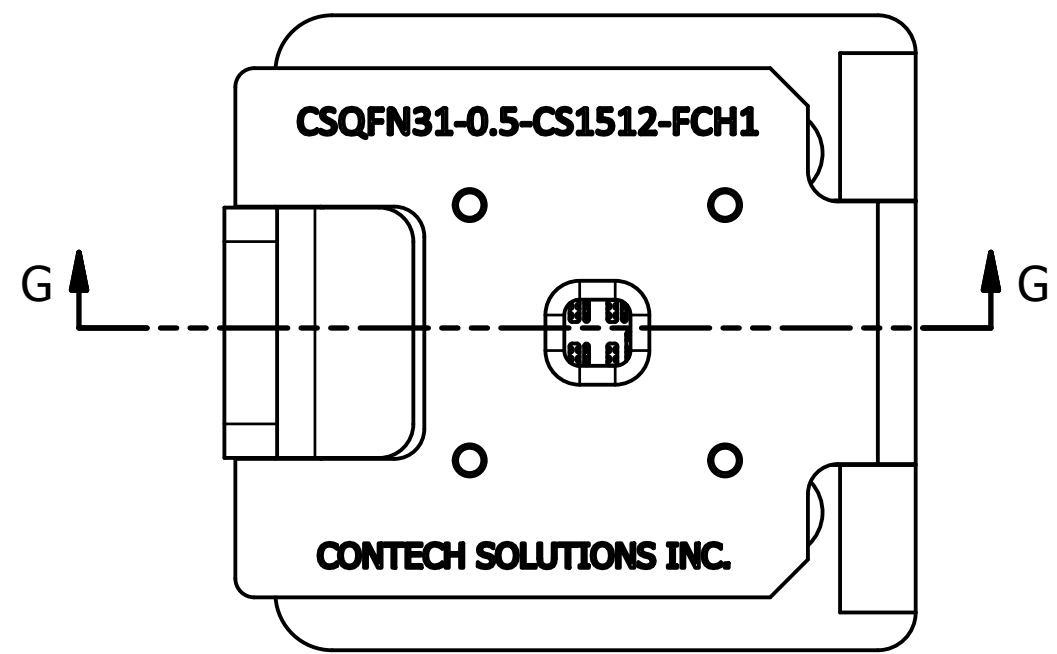

DETAIL H
SCALE 12 : 1

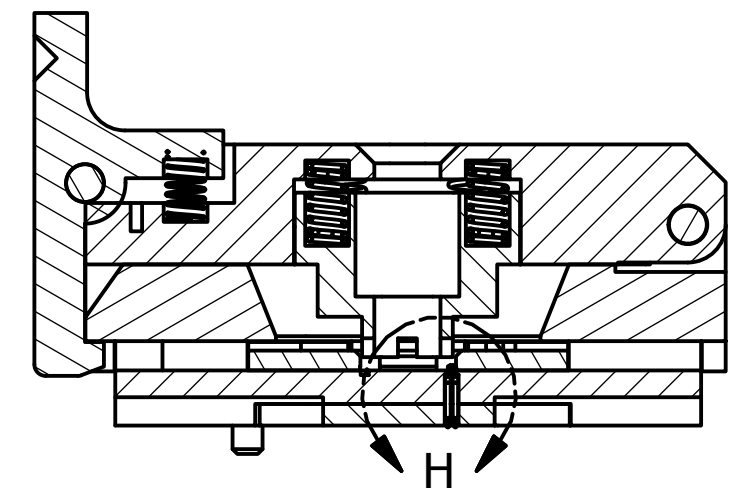

SECTION G-G
SCALE 2.5 : 1

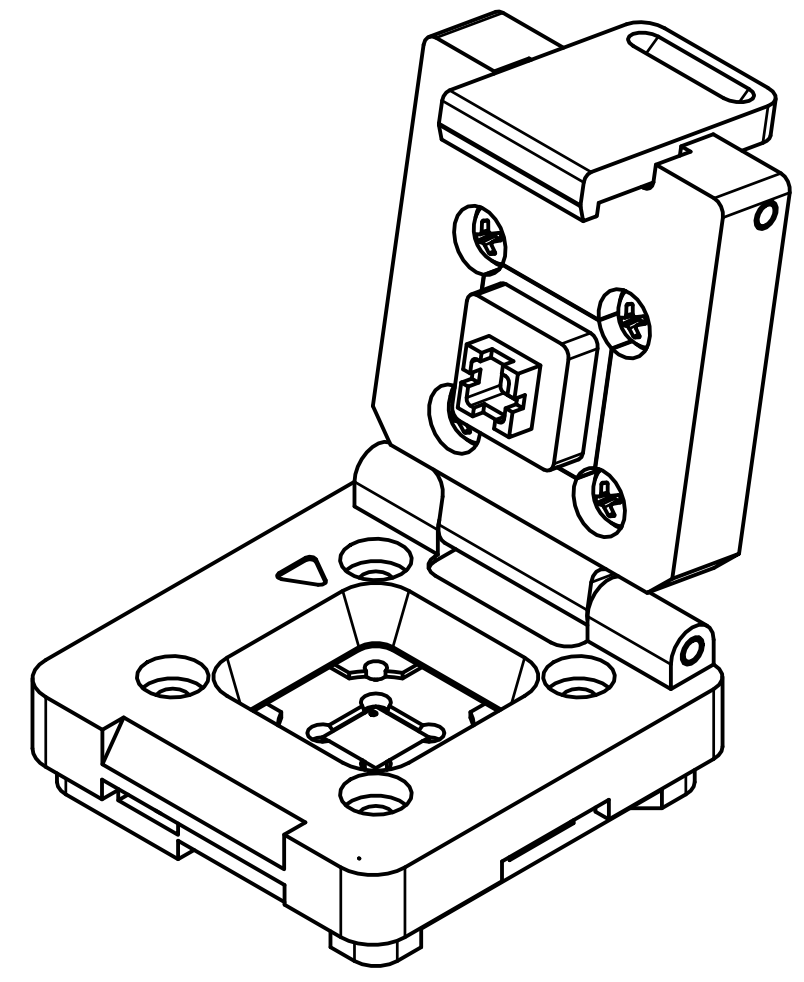

UNLESS OTHERWISE SPECIFIED DIMENSIONS ARE IN MILLIMETERS	DRAWN V Mojica	8/15/2016	 Contech Solutions Incorporated 631 Montague avenue San Leandro, Ca 94577
	CHECKED	12/2/2016	
TOLERANCES DECIMALS .X ± .1 .XX ± .05 .XXX ± .030 ANGLES ±1°	QA		TITLE
	MFG		PN# CSQFN31-0.5-CS1512-FCH1
	APPROVED		SIZE C
	MATERIAL		DWG NO CSQFN31-CS1512-FCH1
			REV A3
			SCALE
			SHEET 7 OF 9

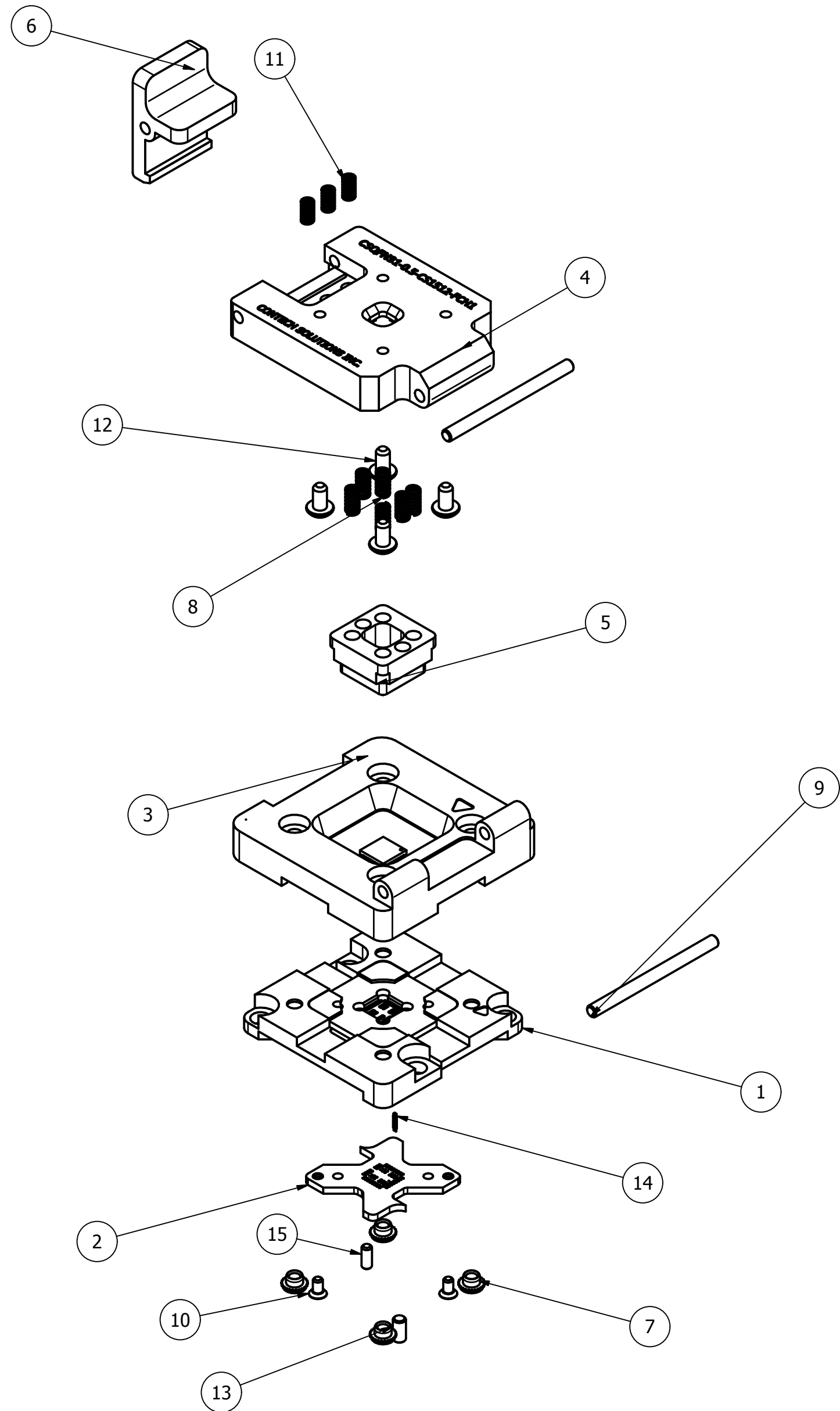

PARTS LIST			
ITEM	QTY	PART NUMBER	DESCRIPTION
1	1	CSQFN31-CS1512-FCH1-001	CONTACTOR-TORLON 4203
2	1	CSQFN31-CS1512-FCH1-002	PIN RETAINER-TORLON 4203
3	1	CSQFN31-CS1512-FCH1-003	LID BASE -BLACK ULTEM
4	1	CSQFN31-CS1512-FCH1-004	LID , BLACK ULTEM
5	1	CSQFN31-CS1512-FCH1-005	PLUNGER , BLACK ULTEM
6	1	CS-520-335-1-L	LATCH - BLACK ULTEM
7	4	U-256-0	#2-56 MICRO SELF CLINCHING NUT
8	6	C03-012-008	COMPRESSION SPRING RATE @ 11.10 lbs/in
9	2	2R30DOWS	Ø2.00MM X 30.00MM L STNLS DOWEL PIN
10	2	0F125PFVS	#0-80 UNC X 1/8 PHIL FLAT HD
11	3	N-2	COMPRESSION SPRING
12	4	2C18PNHD	#2-56 X 1/4" UNC PHIL PAN HEAD SCREW
13	1	2R4DOWS	Ø2.00MM X 4.00MM L STNLS DOWEL PIN
14	79	CS1512-T2	PIN CONTACT
15	1	06R15DOWS	Ø1/16 X 5/32 L STNLS DOWEL PIN

UNLESS OTHERWISE SPECIFIED DIMENSIONS ARE IN MILLIMETERS TOLERANCES DECIMALS .X ± .1 .XX ± .05 .XXX ± .030 ANGLES ±1°	DRAWN V Mojica 8/15/2016	 Contech Solutions Incorporated 631 Montague avenue San Leandro, Ca 94577	TITLE PN# CSQFN31-0.5-CS1512-FCH1			
	CHECKED 12/2/2016				QA	
	MFG		APPROVED	SIZE C	DWG NO CSQFN31-CS1512-FCH1	REV A3
	MATERIAL		SCALE	SHEET 8 OF 9		

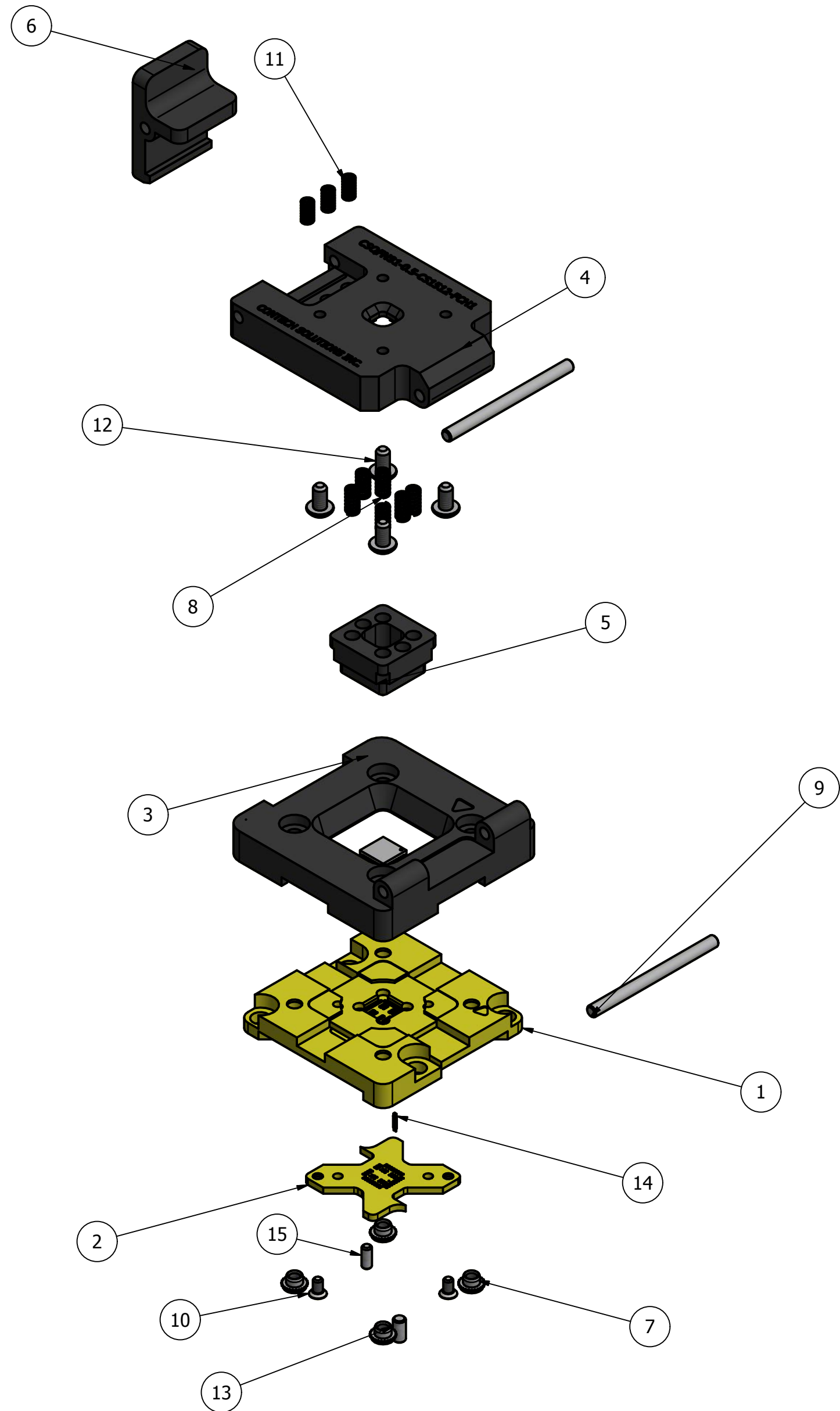

PARTS LIST			
ITEM	QTY	PART NUMBER	DESCRIPTION
1	1	CSQFN31-CS1512-FCH1-001	CONTACTOR-TORLON 4203
2	1	CSQFN31-CS1512-FCH1-002	PIN RETAINER-TORLON 4203
3	1	CSQFN31-CS1512-FCH1-003	LID BASE -BLACK ULTEM
4	1	CSQFN31-CS1512-FCH1-004	LID , BLACK ULTEM
5	1	CSQFN31-CS1512-FCH1-005	PLUNGER , BLACK ULTEM
6	1	CS-520-335-1-L	LATCH - BLACK ULTEM
7	4	U-256-0	#2-56 MICRO SELF CLINCHING NUT
8	6	C03-012-008	COMPRESSION SPRING RATE @ 11.10 lbs/in
9	2	2R30DOWS	Ø2.00MM X 30.00MM L STNLS DOWEL PIN
10	2	0F125PFVS	#0-80 UNC X 1/8 PHIL FLAT HD
11	3	N-2	COMPRESSION SPRING
12	4	2C18PNHD	#2-56 X 1/4" UNC PHIL PAN HEAD SCREW
13	1	2R4DOWS	Ø2.00MM X 4.00MM L STNLS DOWEL PIN
14	79	CS1512-T2	PIN CONTACT
15	1	06R15DOWS	Ø1/16 X 5/32 L STNLS DOWEL PIN

UNLESS OTHERWISE SPECIFIED DIMENSIONS ARE IN MILLIMETERS TOLERANCES DECIMALS .X ± .1 .XX ± .05 .XXX ± .030 ANGLES ±1'	DRAWN V Mojica 8/15/2016	 Contech Solutions Incorporated 631 Montague avenue San Leandro, Ca 94577
	CHECKED 12/2/2016	
	QA 	
	MFG 	
APPROVED 		TITLE PN# CSQFN31-0.5-CS1512-FCH1
MATERIAL 		SIZE C DWG NO CSQFN31-CS1512-FCH1 REV A3
SCALE 		SHEET 9 OF 9