

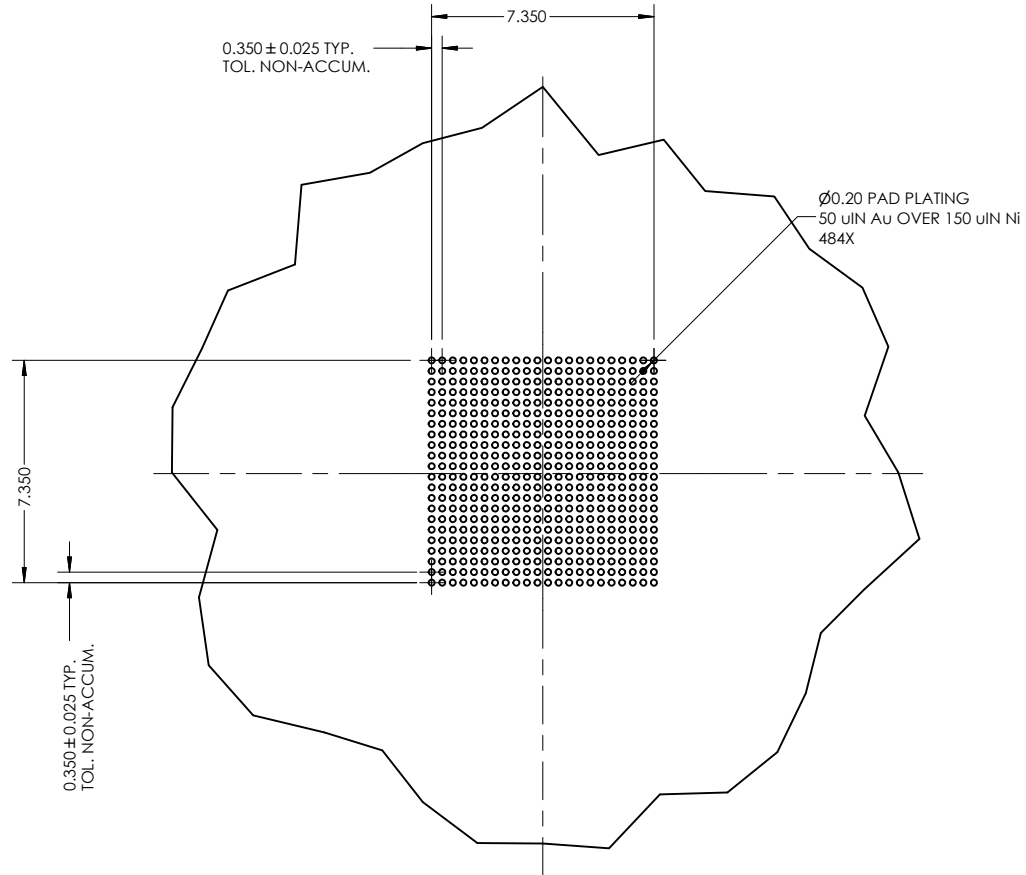

UNLESS OTHERWISE SPECIFIED DIMENSIONS ARE IN MILLIMETERS TOLERANCES DECIMALS .X ± .1 .XX ± .05 .XXX ± .030 ANGLES ±1'	DRAWN V. MOJICA	7/4/2016	 Contech Solutions Incorporated 631 Montague avenue San Leandro, Ca 94577	
	CHECKED	8/26/2016		
	QA		TITLE	CUSTOM SOCKET DRAWING PN# CSBGA484-0.35-CSW035-AVG1
	MFG		SIZE	DWG NO CSBGA484-CSW035-AVG1
APPROVED		SCALE	REV A2	
MATERIAL			SHEET 1 OF 12	

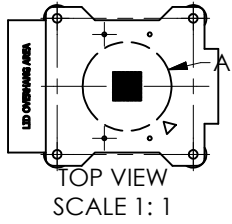

DETAIL A
SCALE 8:1

UNLESS OTHERWISE SPECIFIED DIMENSIONS ARE IN MILLIMETERS TOLERANCES DECIMALS .X ± .1 .XX ± .05 .XXX ± .030 ANGLES ±1°	DRAWN	V. MOJICA	7/4/2016	 Contech Solutions Incorporated 631 Montague avenue San Leandro, Ca 94577		
	CHECKED		8/26/2016			
	QA			TITLE	CUSTOM SOCKET DRAWING PN# CSBGA484-0.35-CSW035-AVG1	
	MFG			SIZE	C	
	APPROVED			DWG NO	CSBGA484-CSW035-AVG1	
MATERIAL			SCALE		REV	A2
				SHEET 2 OF 12		

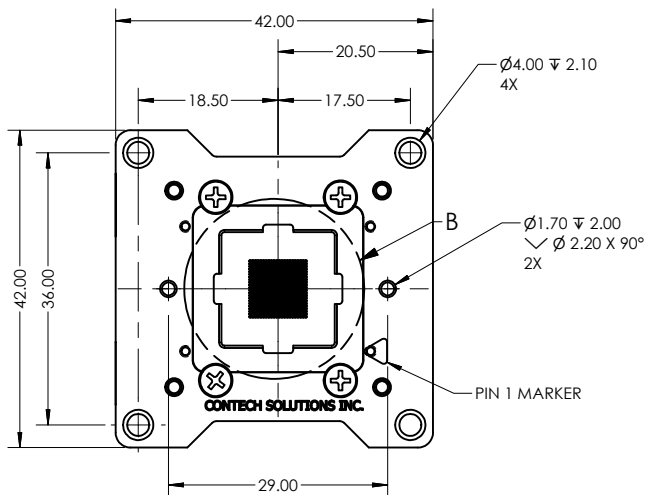

TOP VIEW
SCALE 2 : 1

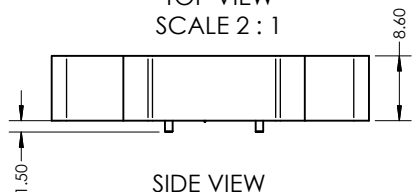

SIDE VIEW
SCALE 2 : 1

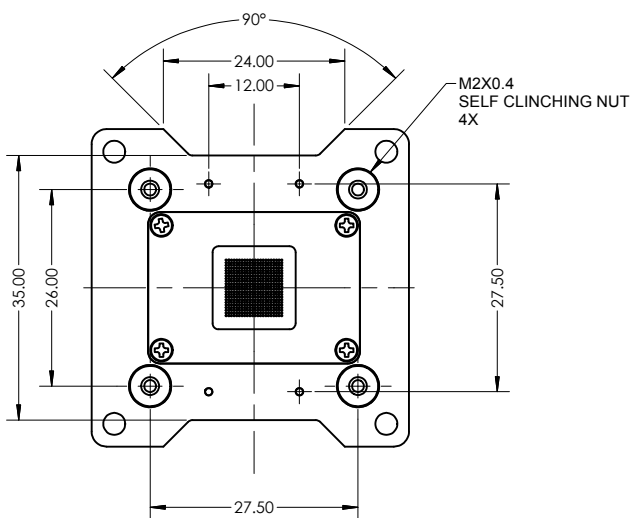

BOTTOM VIEW
SCALE 2 : 1

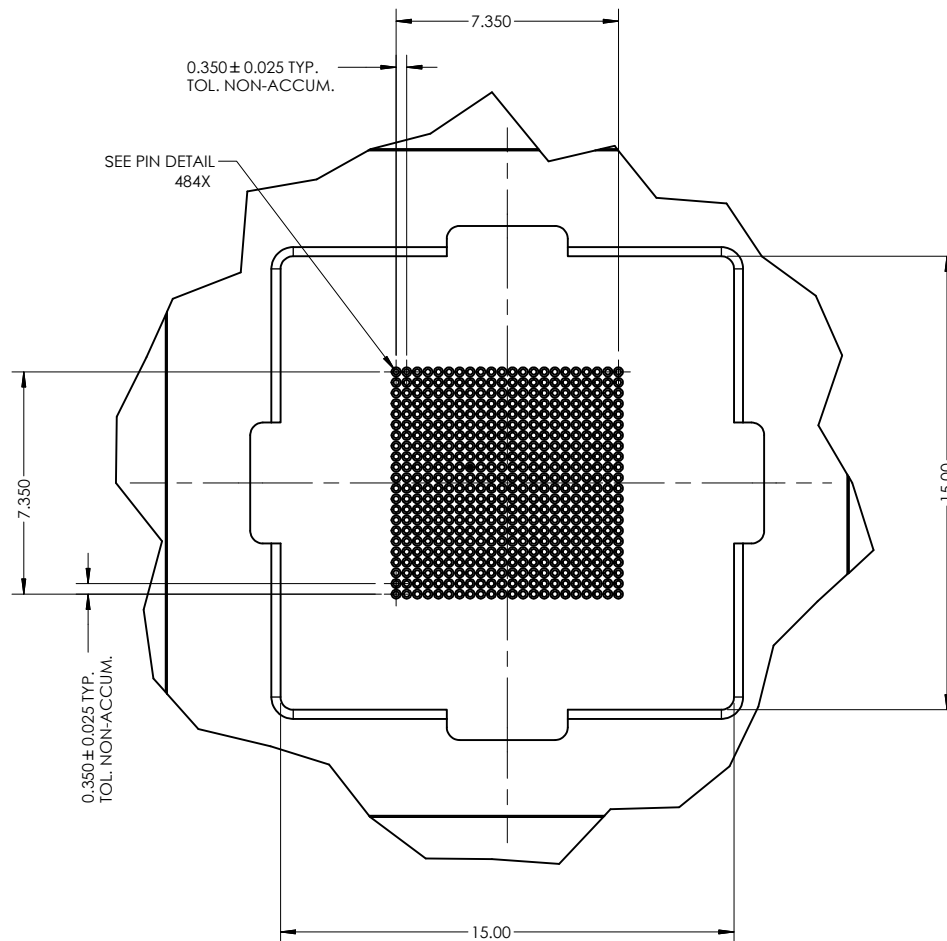

DETAIL B
SCALE 8 : 1

UNLESS OTHERWISE SPECIFIED DIMENSIONS ARE IN MILLIMETERS TOLERANCES DECIMALS .X \pm .1 .XX \pm .05 .XXX \pm .030 ANGLES #1'	DRAWN V. MOJICA	7/4/2016	 Contech Solutions Incorporated 631 Montague Avenue San Leandro, Ca 94577	
	CHECKED	8/26/2016		
	QA		TITLE	CUSTOM SOCKET DRAWING PN# CSBGA484-0.35-CSW035-AVG1
	MFG		SIZE	C
APPROVED		DWG NO	CSBGA484-CSW035-AVG1	
MATERIAL TORLON 4203		SCALE	A2	
			SHEET 3 OF 12	

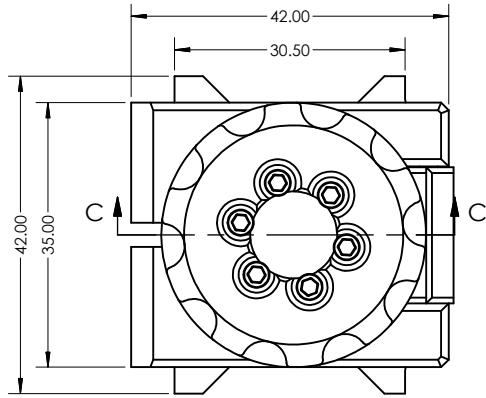

TOP VIEW
SCALE 2 : 1

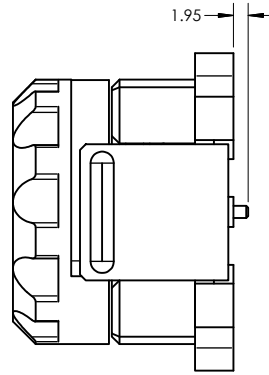

SIDE VIEW
SCALE 2 : 1

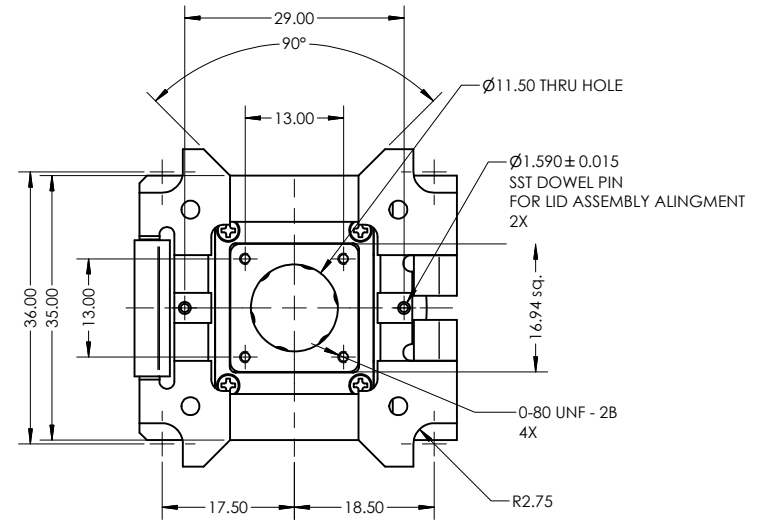

BOTTOM VIEW
SCALE 2 : 1

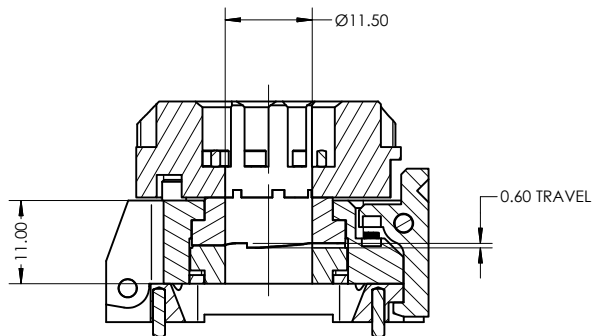

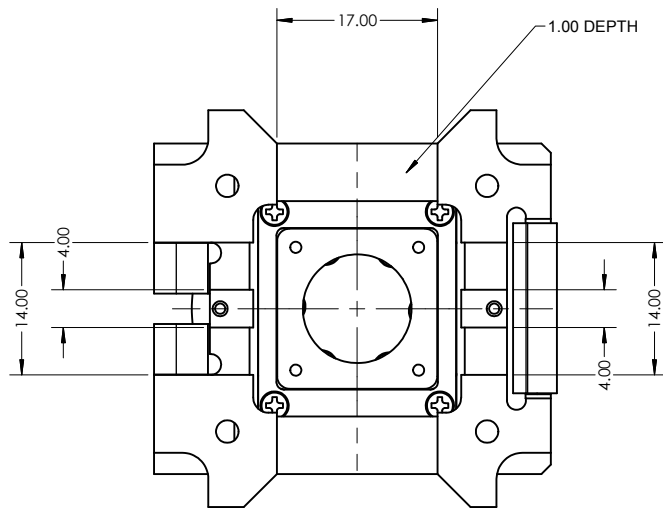

SECTION C-C
SCALE 2 : 1

UNLESS OTHERWISE SPECIFIED DIMENSIONS ARE IN MILLIMETERS TOLERANCES DECIMALS .X ± .1 .XX ± .05 .XXX ± .030 ANGLES ±1°	DRAWN V. MOJICA	7/4/2016	 Contech Solutions Incorporated 631 Montague avenue San Leandro, Ca 94577	
	CHECKED	8/26/2016		
	QA		TITLE	CUSTOM SOCKET DRAWING PN# CSBGA484-0.35-CSW035-AVG1
	MFG		SIZE	C
	APPROVED		DWG NO	CSBGA484-CSW035-AVG1
MATERIAL ALUMINUM 6061		SCALE		REV A2
			SHEET 4 OF 12	

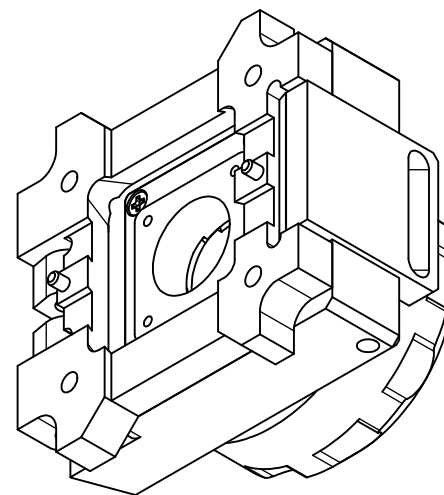

BOTTOM VIEW
SCALE 2.5 : 1
LID ASSEMBLY



UNLESS OTHERWISE SPECIFIED DIMENSIONS ARE IN MILLIMETERS TOLERANCES DECIMALS .X ± .1 .XX ± .05 .XXX ± .030 ANGLES ±1'	DRAWN V. MOJICA	7/4/2016	 Contech Solutions Incorporated 631 Montague avenue San Leandro, Ca 94577	
	CHECKED	8/26/2016		
	QA		TITLE	CUSTOM SOCKET DRAWING PN# CSBGA484-0.35-CSW035-AVG1
	MFG		SIZE	DWG NO
APPROVED		C	CSBGA484-CSW035-AVG1	A2
MATERIAL		SCALE	SHEET 5 OF 12	

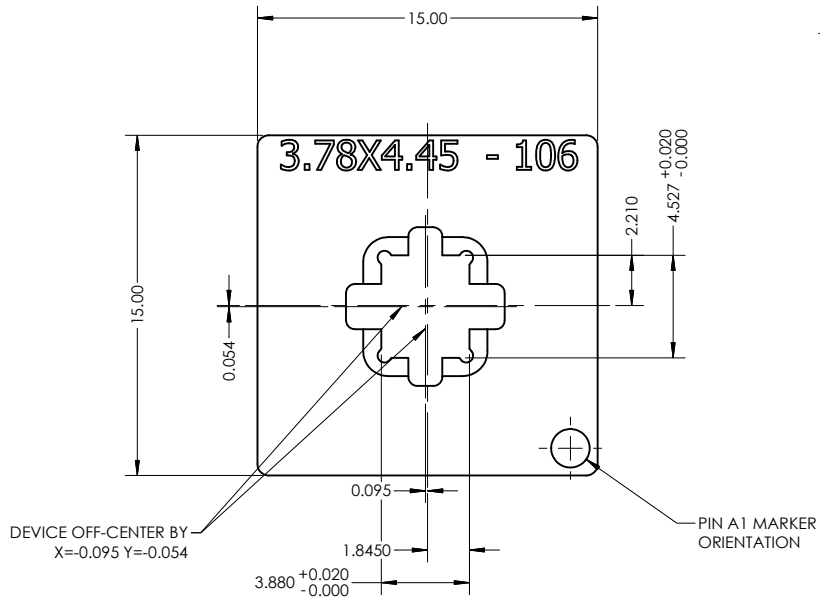

TOP VIEW
SCALE 6 : 1

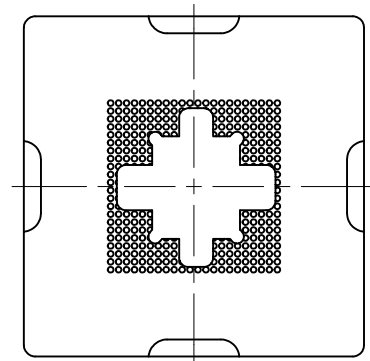
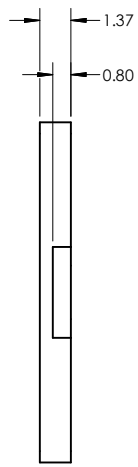

UNLESS OTHERWISE SPECIFIED DIMENSIONS ARE IN MILLIMETERS TOLERANCES DECIMALS .X ± .1 .XX ± .05 .XXX ± .030 ANGLES ±1'	DRAWN V. MOJICA	7/4/2016	 Contech Solutions Incorporated 631 Montague avenue San Leandro, Ca 94577		
	CHECKED	8/26/2016			
	QA		TITLE		
	MFG		CUSTOM SOCKET DRAWING PN# CSBGA484-0.35-CSW035-AVG1		
APPROVED		SIZE	DWG NO	REV	
MATERIAL		C	CSBGA484-CSW035-AVG1	A2	
		SCALE	SHEET 6 OF 12		

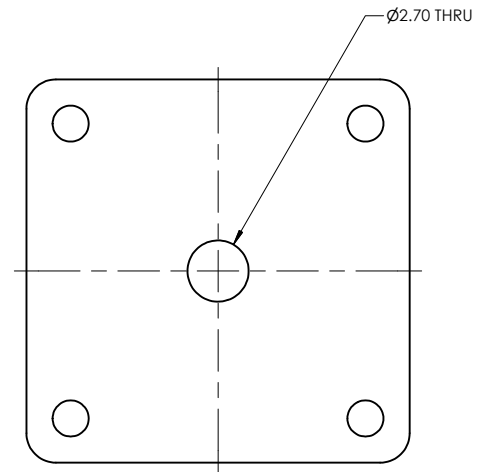
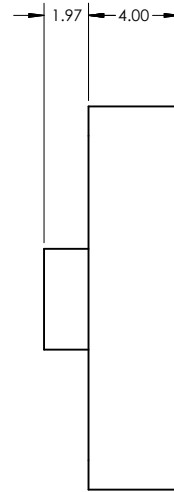
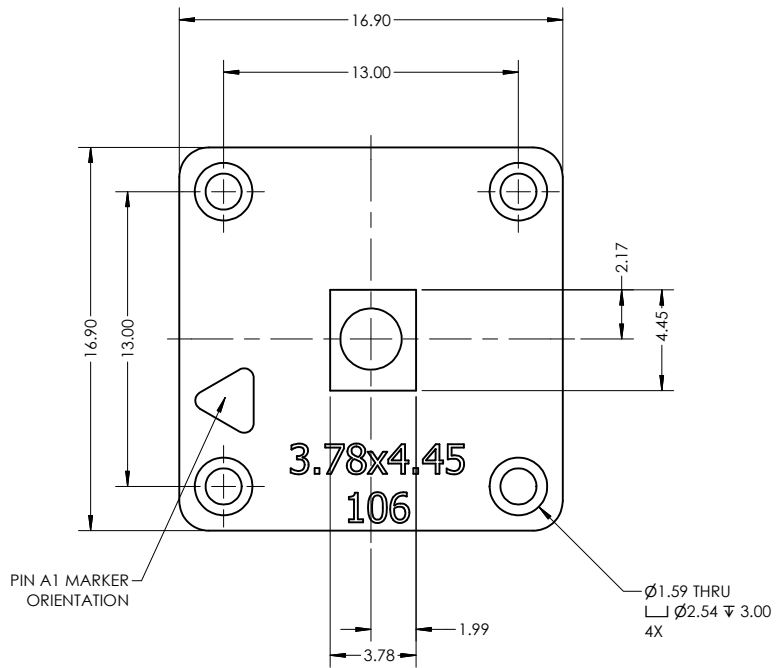

UNLESS OTHERWISE SPECIFIED DIMENSIONS ARE IN MILLIMETERS TOLERANCES DECIMALS .X ± .1 .XX ± .05 .XXX ± .030 ANGLES ±1'	DRAWN V. MOJICA	7/4/2016	 Contech Solutions Incorporated 631 Montague avenue San Leandro, Ca 94577	
	CHECKED	8/26/2016		
	QA		TITLE	CUSTOM SOCKET DRAWING PN# CSBGA484-0.35-CSW035-AVG1
	MFG		SIZE	C
APPROVED		DWG NO	CSBGA484-CSW035-AVG1	
MATERIAL		REV	A2	
		SCALE	SHEET 7 OF 12	

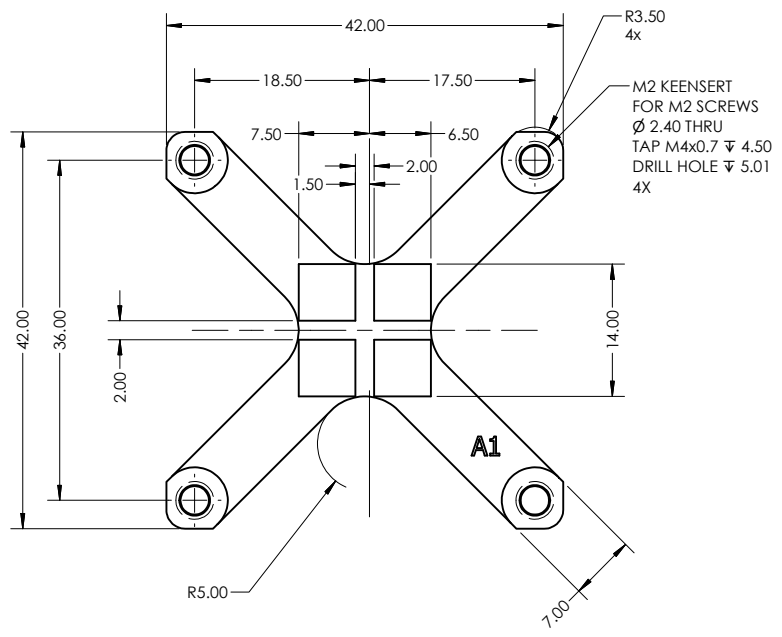

TOP VIEW
SCALE 2.5 : 1

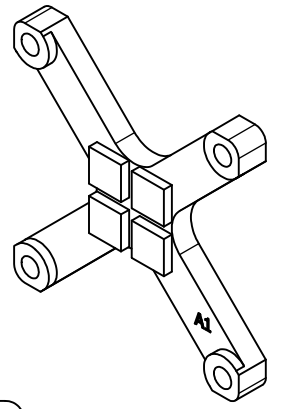
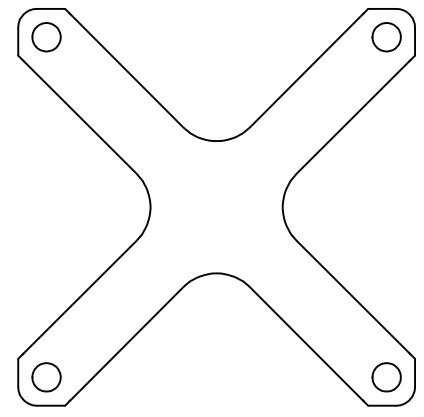
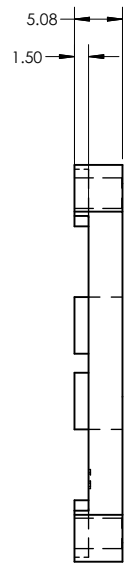

BACKUP PLATE:
 1- MATERIAL : ALUMINUM 6061-T6
 2- FINISH : RED ANODIZED

UNLESS OTHERWISE SPECIFIED DIMENSIONS ARE IN MILLIMETERS TOLERANCES DECIMALS .X \pm .1 .XX \pm .05 .XXX \pm .030 ANGLES \pm 1'	DRAWN	V. MOJICA	7/4/2016	Contech Solutions Incorporated 631 Montague avenue San Leandro, Ca 94577				
	CHECKED		8/26/2016					
	QA			TITLE	CUSTOM SOCKET DRAWING PN# CSBGA484-0.35-CSW035-AVG1			
	MFG			SIZE	C	DWG NO	CSBGA484-CSW035-AVG1	REV
	APPROVED			SCALE			SHEET 8 OF 12	

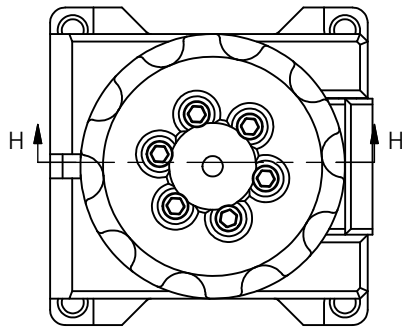

TOP VIEW
SCALE 2: 1

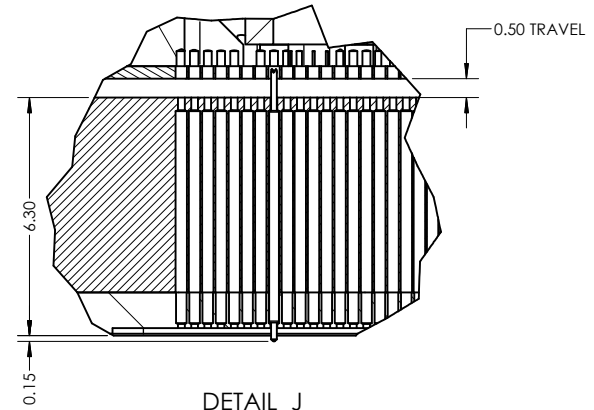

DETAIL J
SCALE 10: 1

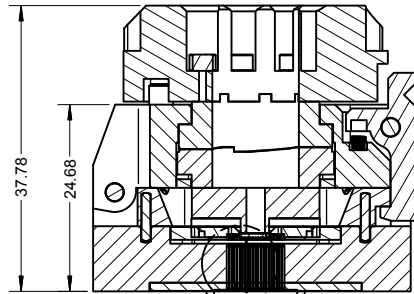

SECTION H-H
SCALE 2: 1

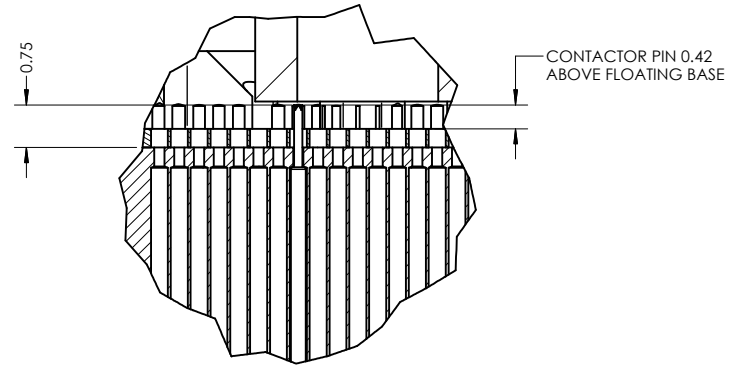

DETAIL L
SCALE 15: 1

UNLESS OTHERWISE SPECIFIED DIMENSIONS ARE IN MILLIMETERS TOLERANCES DECIMALS .X ± .1 .XX ± .05 .XXX ± .030 ANGLES ±1°	DRAWN V. MOJICA	7/4/2016	 Contech Solutions Incorporated 631 Montague avenue San Leandro, Ca 94577	
	CHECKED	8/26/2016		
	QA		TITLE	CUSTOM SOCKET DRAWING PN# CSBGA484-0.35-CSW035-AVG1
	MFG		SIZE	DWG NO
	APPROVED		C	CSBGA484-CSW035-AVG1
MATERIAL		SCALE	REV	A2
			SHEET 9 OF 12	

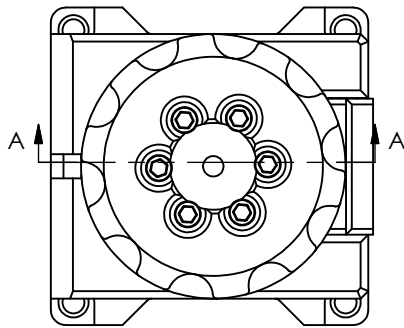

TOP VIEW
SCALE 2: 1

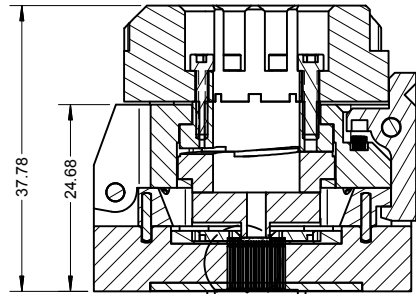

SECTION A-A
SCALE 2: 1

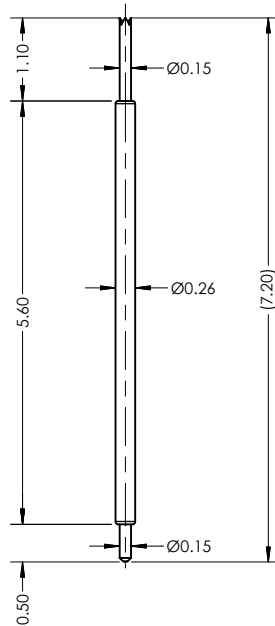

CONTACT DETAIL
SCALE 20 : 1

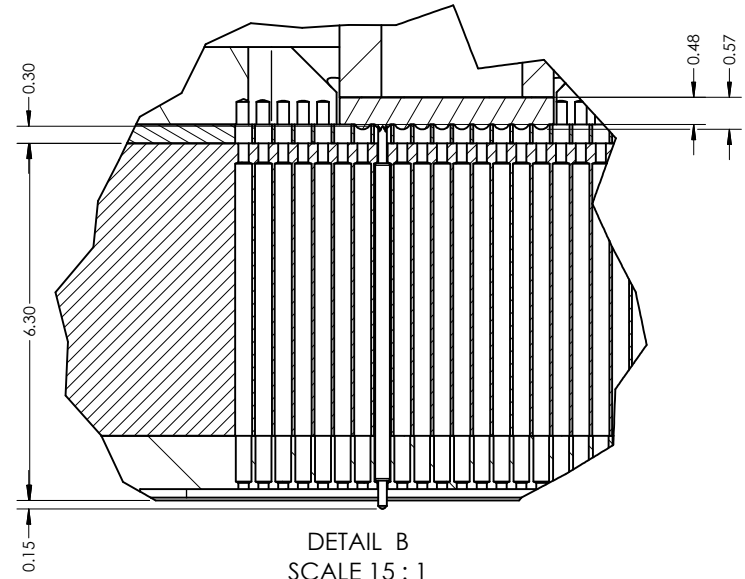

DETAIL B
SCALE 15 : 1

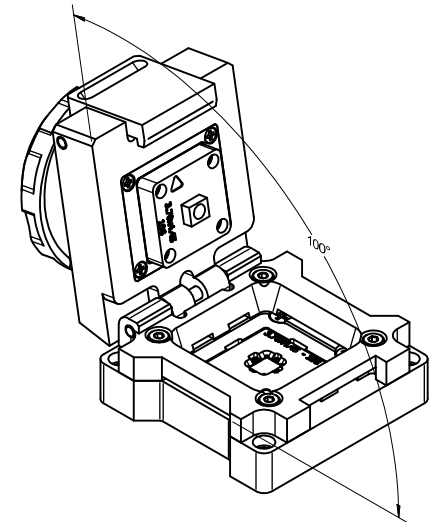
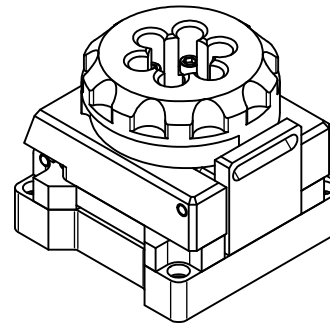

UNLESS OTHERWISE SPECIFIED DIMENSIONS ARE IN MILLIMETERS TOLERANCES DECIMALS .X ± .1 .XX ± .05 .XXX ± .030 ANGLES ≠ 1°	DRAWN V. MOJICA	7/4/2016	 Contech Solutions Incorporated 631 Montague Avenue San Leandro, Ca 94577	
	CHECKED	8/26/2016		
	QA		TITLE	CUSTOM SOCKET DRAWING PN# CSBGA484-0.35-CSW035-AVG1
	MFG		SIZE	C
APPROVED		DWG NO	CSBGA484-CSW035-AVG1	
MATERIAL		SCALE		
			REV A2	
			SHEET 10 OF 12	

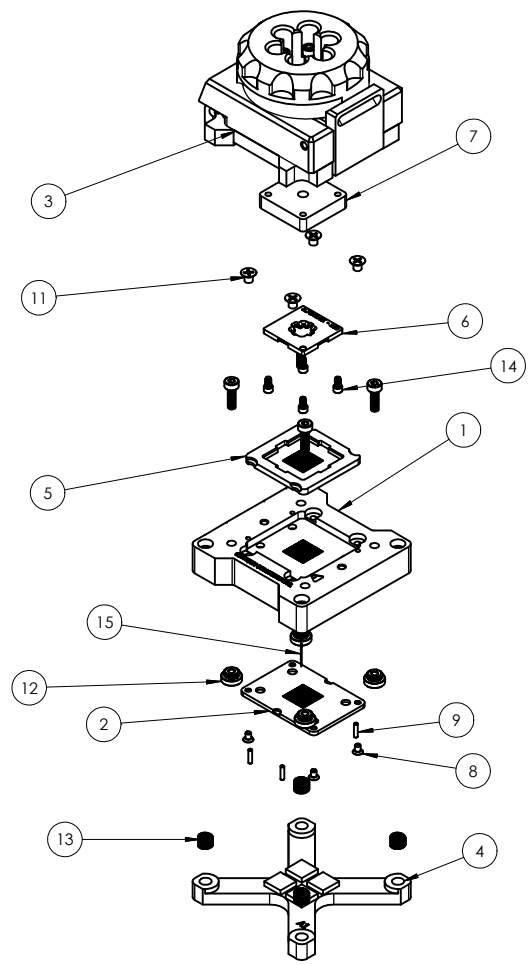

PARTS LIST			
ITEM	QTY	PART NUMBER	DESCRIPTION
1	1	CSBGA484-CSW035-AVG1-001	CONTACTOR BASE, TORLON 4203
2	1	CSBGA484-CSW035-AVG1-002	PIN RETAINER, TORLON 4203
3	1	CSBGA484-CSW035-AVG1-003	LID ASSEMBLY , ALUMINUM 6061 ANODIZED RED
4	1	CSBGA484-CSW035-AVG1-004	BACKUP PLATE , ALUMINUM 6061 - RED ANODIZED
5	1	CSBGA484-CSW035-AVG1-005	FLOATING BASE, TORLON 4203
6	1	CSBGA484-CSW035-AVG1-006	3.78 x 4.45 - 106 GUIDE PLATE, TORLON 4203
7	1	CSBGA484-CSW035-AVG1-007	PLUNGER 3.78x4.45 - 106, TORLON 4203
8	8	0F9PFVS	#0-80 UNC X 3/32" PHIL FLAT STNLS
9	4	93600A030	M1 X 4MM L SST DOWEL PIN
10	4	N-2	COMPRESSION SPRING
11	4	2C12PFVS	#2-56 UNC X 1/8" PHIL FLAT HD STNLS-MODDED
12	4	CKFS2M2	M2x0.4 SST SELF CLINCHING NUT
13	4	KNCM2X0.4	KEENSERT M2 X 0.40
14	4	0F12SSHCS	#0-80 UNC X 1/8 SOC CAP STNLS
15	484	CSW035-001C2	CONTACT DETAIL
16	4	91290A014	SOCKET HEAD CAP SCREW, M2 THREAD, 7mm LENGTH, 0.4mm PITCH

UNLESS OTHERWISE SPECIFIED DIMENSIONS ARE IN MILLIMETERS TOLERANCES DECIMALS .X ± .1 .XX ± .05 .XXX ± .030 ANGLES ±1°	DRAWN	V. MOJICA	7/4/2016	 Contech Solutions Incorporated 631 Montague avenue San Leandro, Ca 94577					
	CHECKED		8/26/2016						
	QA								
	MFG								
APPROVED				TITLE	CUSTOM SOCKET DRAWING PN# CSBGA484-0.35-CSW035-AVG1				
MATERIAL				SIZE	C	DWG NO	CSBGA484-CSW035-AVG1	REV	A2
				SCALE				SHEET 11 OF 12	

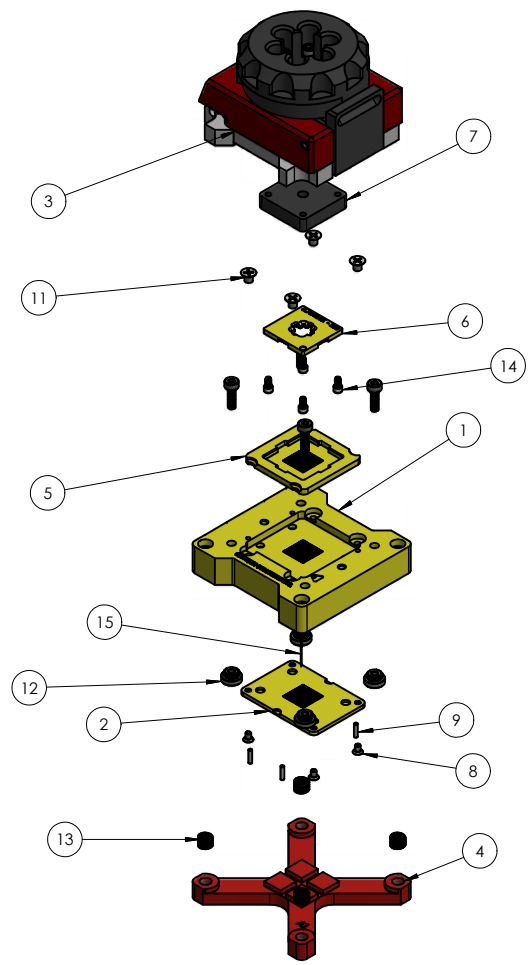

PARTS LIST			
ITEM	QTY	PART NUMBER	DESCRIPTION
1	1	CSBGA484-CSW035-AVG1-001	CONTACTOR BASE, TORLON 4203
2	1	CSBGA484-CSW035-AVG1-002	PIN RETAINER, TORLON 4203
3	1	CSBGA484-CSW035-AVG1-003	LID ASSEMBLY , ALUMINUM 6061 ANODIZED RED
4	1	CSBGA484-CSW035-AVG1-004	BACKUP PLATE , ALUMINUM 6061 - RED ANODIZED
5	1	CSBGA484-CSW035-AVG1-005	FLOATING BASE, TORLON 4203
6	1	CSBGA484-CSW035-AVG1-006	3.78 x 4.45 -106 GUIDE PLATE, TORLON 4203
7	1	CSBGA484-CSW035-AVG1-007	PLUNGER 3.78x4.45 - 106, TORLON 4203
8	8	0F9PFV5	#0-80 UNC X 3/32" PHIL FLAT STNLS
9	4	93600A030	M1 X 4MM L SST DOWEL PIN
10	4	N-2	COMPRESSION SPRING
11	4	2C12PFV5	#2-56 UNC X 1/8" PHIL FLAT HD STNLS-MODDED
12	4	CKFS2M2	M2x0.4 SST SELF CLINCHING NUT
13	4	KNCM2X0.4	KEENSERT M2 X 0.40
14	4	0F12SSHCS	#0-80 UNC X 1/8 SOC CAP STNLS
15	484	CSW035-001C2	CONTACT DETAIL
16	4	91290A014	SOCKET HEAD CAP SCREW, M2 THREAD, 7mm LENGTH, 0.4mm PITCH

UNLESS OTHERWISE SPECIFIED DIMENSIONS ARE IN MILLIMETERS TOLERANCES DECIMALS .X ± .1 .XX ± .05 .XXX ± .030 ANGLES ±1°	DRAWN	V. MOJICA	7/4/2016	 Contech Solutions Incorporated 631 Montague avenue San Leandro, Ca 94577					
	CHECKED		8/26/2016						
	QA								
	MFG								
APPROVED				TITLE	CUSTOM SOCKET DRAWING PN# CSBGA484-0.35-CSW035-AVG1				
MATERIAL				SIZE	C	DWG NO	CSBGA484-CSW035-AVG1	REV	A2
				SCALE				SHEET 12 OF 12	